

USB DiskOnModule HBH41 Series (Horizontal)



Table of Contents

- 1. Product Description 1**
 - 1.1 Product Overview..... 1
 - 1.2 Product Features 1
 - 1.3 System Requirement 2
- 2. Feature..... 3**
 - 2.1 Physical Specifications..... 3
 - 2.2 Electronic Specifications 4
 - 2.3 Performance Specifications 6
- 3. Function 8**
 - 3.1 Switch Setting 8
 - 3.2 Pin Signal Assignment 8
- 4. Flash Management Technology..... 9**
- 5. Installation..... 9**
 - 5.1 Installation..... 9
- 6. Ordering Information..... 10**
- 7. Contact Information..... 11**

List of Figures

Figure 1: USB DiskOnModule Overlook Diagram.....3

Figure 2: USB DiskOnModule Dimension4

Figure 3: USB DiskOnModule Block Diagram5

Figure 4: Write Protection Switch8

Figure 5: USB Pin Signal Assignment8

List of Tables

Table 1: USB DiskOnModule Physical Dimension 4

Table 2: USB DiskOnModule Power Consumption 5

Table 3: USB connector pin definitions 8

Table 4: HBH41 Ordering Information..... 10

Revision	Date	Major Changes
1.1	2009/1/23	1.Update product model form BH41 to HBH41. 2.Update capacity to 512MB~1GB. 3.Add dimension of screw hole on figure 2
A.0	2009/3/17	1. Revise the notice in Section 2.6 2. Update contact information in Section 7
A.1	2009/4/9	1.Revise the notice in Section 2.6 2. Update contact information in Section 7

Copyright Information

Copyright © 2009, CoreSolid Storage Corporation. All rights reserved.

The information and specifications provided in this document should be used for comparative analysis and reference purposes. The content of this document is subject to change without prior notice.

1. Product Description

1.1 Product Overview

CSS's USB DiskOnModule HBH41 series is designed with NAND type flash memory technology. This product complies with 10 PIN embedded USB interface on mother-board and is suitable for data storage memory medium for portable system which requires small capacity main storage device or boot disk based on Linux, WinCE operating system. By using DiskOnModule, it is possible to operate good performance for the portable system which has USB interface slots on the mother-board.

HBH41 series USB DiskOnModule is a storage device based on flash memory technology, which emulates an ordinary magnetic hard disk. HBH41 series products provide an all in one module solution for solid-state flash disk. It is suitable for use in portable and embedded systems which have limited space and power consumption.

Unlike IDE drives, no signal cable and extra, special space is required. The HBH41 DiskOnModule is a solid-state solution for USB Hard Disk drive, which has no moving parts. That provides a good stability in a moving system. These products are also free from extra and special algorithm or some firmware driver. Just plug the DiskOnModule into the USB slot and play it. Users can play the DiskOnModule as same as the Hard Disk Drives.

The DiskOnModule family provides the capacities ranging from 512MB up to 16GB.

● Application Fields;

- Industrial PC and Thin Client
- Game and Telecommunication Machine
- Ticketing, Examining, testing machine
- Army, Health and Production Equipment and Machine
- Other machines and Equipments with USB interface slots on mother-board
- Windows Vista ReadyBoost™ Embedded Device on Mother-Board

1.2 Product Features

1. USB Interface:

- 1) Support Standard USB (Universal Serial Bus) interface.
- 2) Fully compatible with USB Specification 2.0/1.1
- 3) Support USB Mass Storage Command Protocol.
- 4) High Speed (480 Mbits/sec), Full Speed (12 Mbits/sec) and Low Speed (1.5 Mbits/sec) transfer support.
- 5) USB Power saving support.
- 6) Support NAND Flash memory with write-protected ability.
- 7) Product type

- Standard type: Right Side Oriented/Left Side Oriented (11mm)

2. Error Correction Logic:

- 1) 13-bit BCH or 8-symbol RS error control coding (ECC).
- 2) Automatic on-the-fly, in-buffer error correction.

1.3 System Requirement

- The Host system which is connected to USB DiskOnModule should meet system requirements at minimum.

1.3.1 Power Requirement

- Voltage: DC 5V

1.3.2 Operating System

- Storage and Boot Disk: Linux, DOS, WinCE, WinXP , WinXP Embedded (Service Pack2)

1.3.3 Interface

- Standard USB 2.0/1.1 Interface (10pin)

2. Feature

2.1 Physical Specifications

Orientation	Height
2GB~8GB(QDP)	9.8mm
8GB~16GB(DSP)	11mm

2.1.1 Overlook

The overlook views of USB DiskOnModule are illustrated in Figure 1.

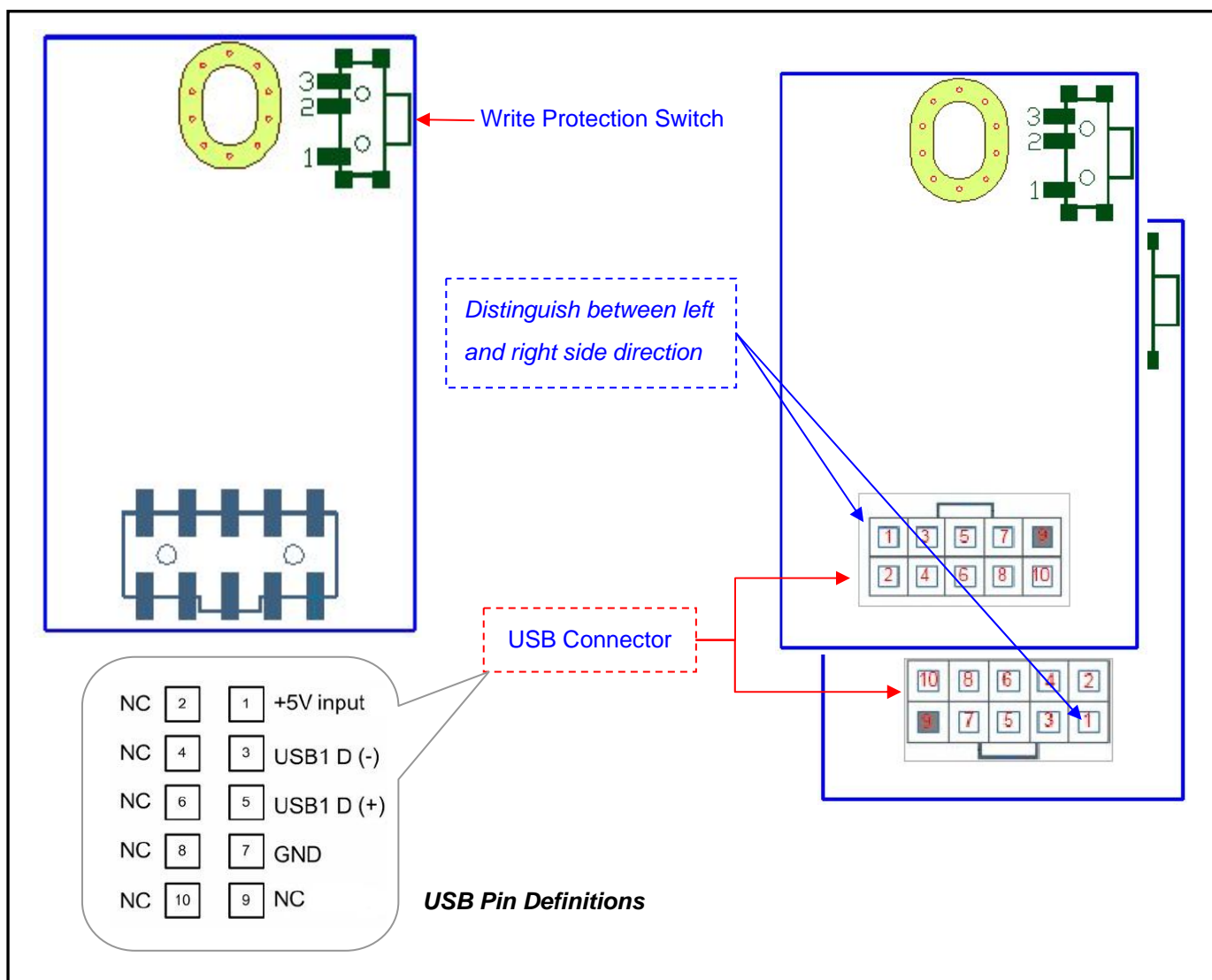

Figure 1: USB DiskOnModule Overlook Diagram

2.1.2 Dimension

The Dimensions of USB DiskOnModule are illustrated in Figure and described in Figure 2 and Table 1.

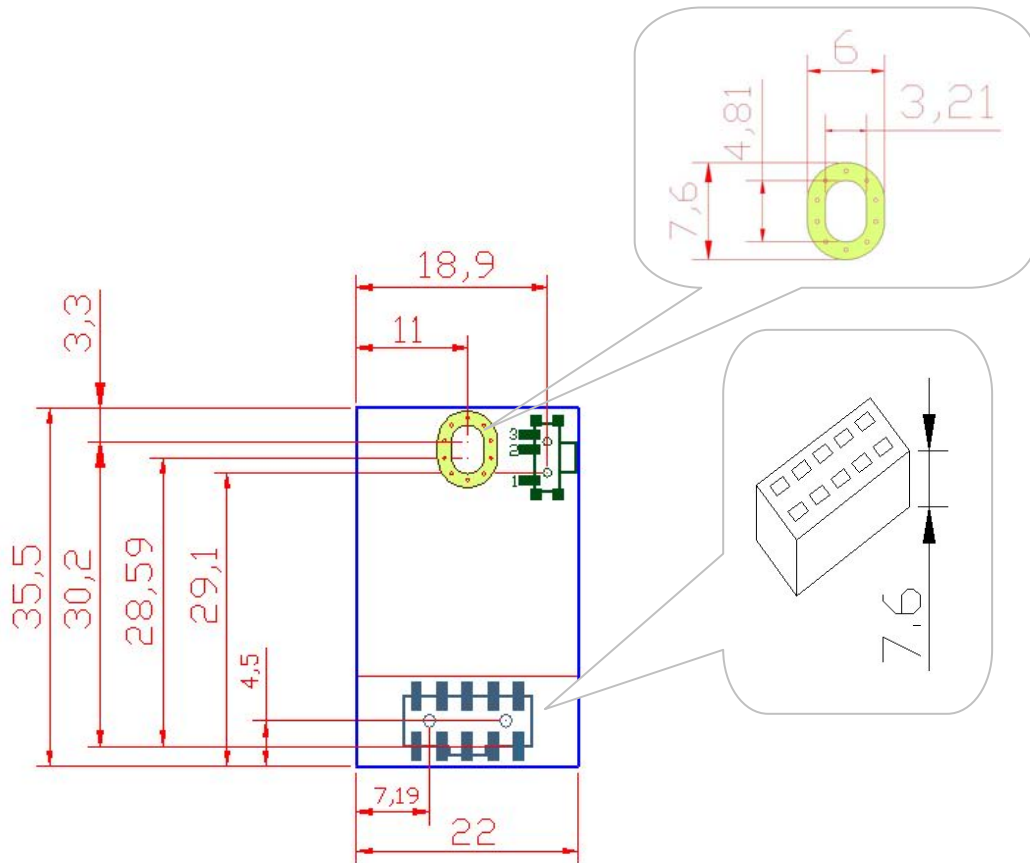

Figure 2: USB DiskOnModule Dimension

Table 1: USB DiskOnModule Physical Dimension

Height	35.5 ± 0.1 mm
Width	22.0 ± 0.1 mm
Thickness	9.8 ± 0.5mm (512MB~8GB for QDP FLASH)
	11.0 ± 0.5mm (8GB~16GB for DSP FLASH)

Notice: All pins are all in dual-in line rows, with 2.54 mm (0.1") pitch.

2.1.3 Weight

- Weight: 5.7g

2.2 Electronic Specifications

2.2.1 Product Definition

USB DiskOnModule is designed to operate and work as Data or Code Storage device by NAND Flash Memory and its Controller through USB 2.0/1.1 Interface to Host Systems.

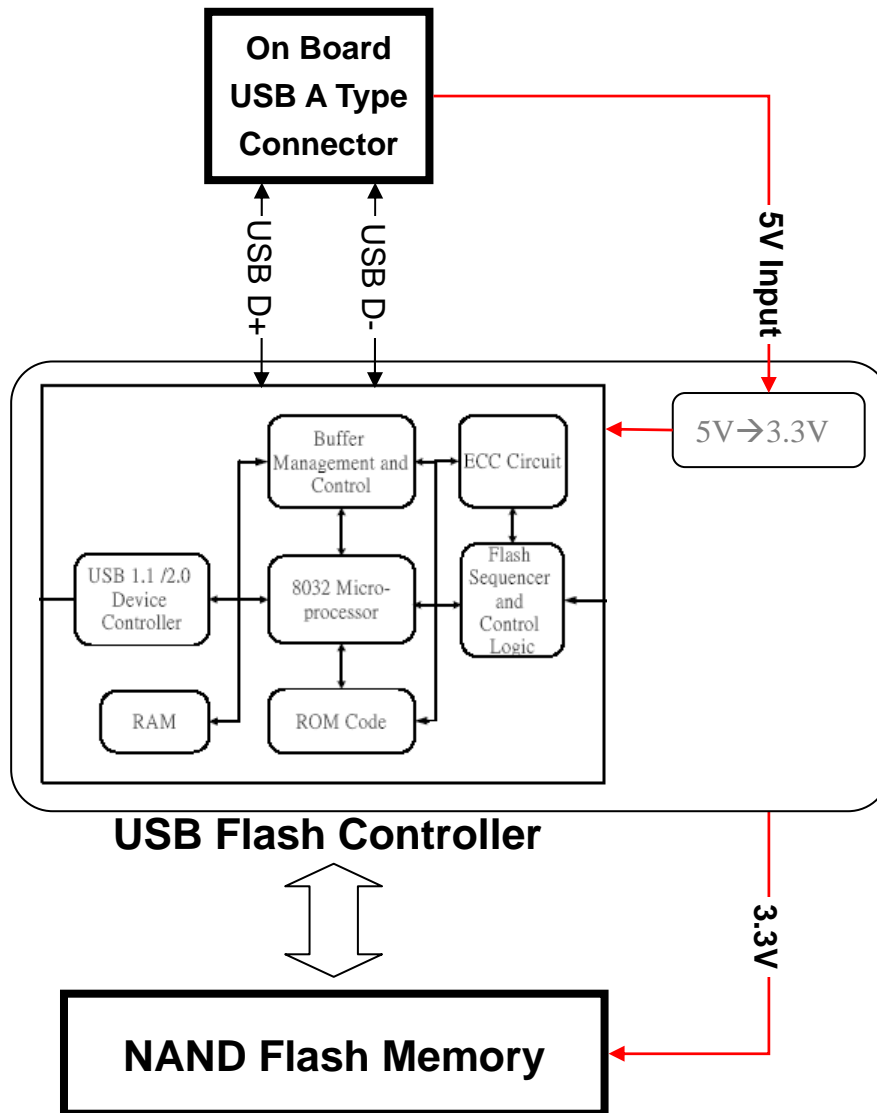

Figure 3: USB DiskOnModule Block Diagram

2.2.2 Operating Voltage

- Voltage DC +5.0V ± 10%

2.2.3 Capacity and Block Size information

- Capacity: 512MBytes ~ 16GBytes

2.2.4 Power Consumption

- DC Information

Table 2: USB DiskOnModule Power Consumption

Mode	Power Consumption
Read	82 mA (typ.)
Write	88 mA (typ.)
Stand by	50 mA (typ.)
Suspend	0.3 mA (typ.)

※ Testing Platform;

- Mother-Board: ASUS P5PE-VM, CPU: Intel Celeron 3GHz, System Memory: DDR2 512MB, Operating System: WinXP, Test Program: HDBENCH 3.xx .

2.3 Performance Specifications

2.3.1 Modes

- USB 2.0/1.1

2.3.2 Data Transfer Time (On USB 2.0 standard)

- Sequential Read: 33 MB/sec
- Sequential Write: 20 MB/sec
- ReadyBoost Rand Read-4KB : 7.43 MB/sec
- ReadyBoost Rand Write-512KB : 14.81 MB/sec

Interface burst transfer rate (High-speed USB Spec Version 2.0): 480Mb/sec

Notice: The value is various bases on the testing platform.

2.3.3 Data Retention

- 10years without requiring power support

Notice: The Value of Data Retention is various bases on the type and manufacturer of Flash Memory

2.3.4 Wear-leveling

- Dynamic Wear-Leveling for same level of Write/Erase Cycle

2.3.5 Bad Block Management

- The Bad Blocks of Flash Memory will be replaced into new ones by controller.

2.4 Environmental Specifications

2.4.1 Temperature

- Operating Temperature: 0°C to +70°C, Non Operating Temperature: -40°C to +85°C

2.4.2 Humidity

- Operating Humidity (30°C Max. Wet Bulb Temp): 10% to 95%
- Non-Operating Humidity (30°C Max. Wet Bulb Temp): 10% to 95% (with no condensation relative humidity)

2.4.3 Bare Drop test

- Test Conditions : 75cm height
- Test Orientation : (Free fell) Front/Rear/Right/Left/Top/Bottom side
- Test Result : Pass

2.4.4 Vibration

- Random Vibration(Operation) : Test Specification

Frequency(Hz)	PSD(G ² /Hz)	Acceleration (Grms)	Dwell Time (Min)
10	0.01	6Grms	30min per axis (X,Y,Z)
100	0.08		
500	0.08		

- Sine Vibration(Non-Operation) : Test Specification

Frequency(Hz)	PSD(G ² /Hz)	Acceleration (G)	Dwell Time (Min)
10	0.01	15Grms	30min per axis (X,Y,Z)
100	0.04		
500	0.04		
2000	0.004		

2.5 Reliability Specifications

2.5.1 ECC/EDC (Error Correction Code/Error Detection Code)

- ECC can provide 13-bit BCH

2.5.2 Read and Write/Erase Cycle

- Read: No Limitation
- Write/Erase: 1,000,000 times

Notice: The Value of Write/Erase Cycle is various bases on the type and manufacturer of Flash Memory.

2.5.3 MTBF (Mean Time Between Failure)

- 2,000,000hours

2.5.4 Power Cycle

- The Power Cycling is tested to 5000 loop. => "Pass"

2.6 Compliance Specifications

- CE
- FCC

Notice: Please contact your closest CSS's office for other certificate information.

3. Function

3.1 Switch Setting

- On case which the switch place “Lock” side, then the data will be read only and can't be written.
- On case of placing in “Open” side, the data will be read and written together.

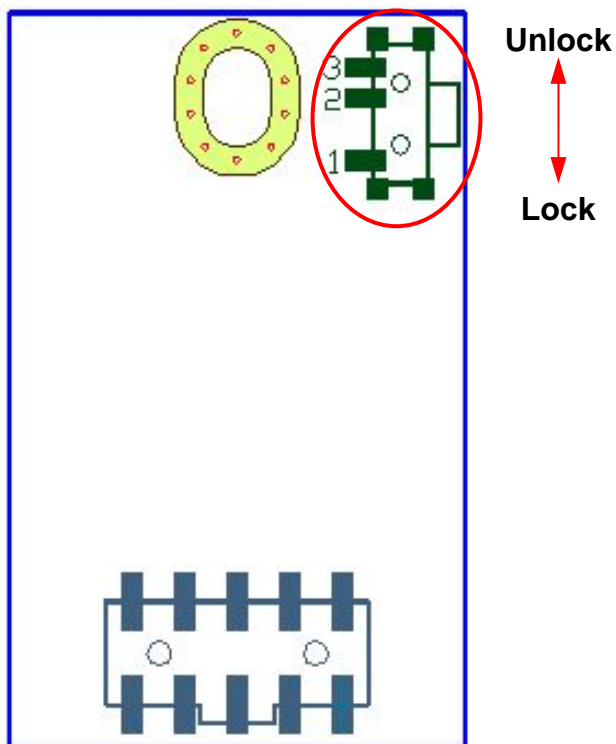

Figure 4: Write Protection Switch

3.2 Pin Signal Assignment

- The signals assigned for USB applications are described in Table 2

Table 3: USB connector pin definitions

Pin No.	Pin Name	Function
1	VCC	USB power input
3	USB D-	USB differential signal
5	USB D+	The pairs are used to transmit Data/Address/Command
7	VSS	Ground

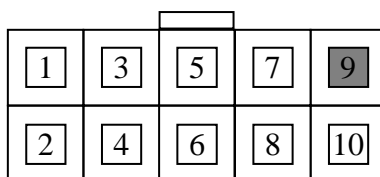

Figure 5: USB Pin Signal Assignment

3.3 Support USB Commands

- USB DiskOnModule works at the operating system compatible to standard USB Commands.

3.4 Windows Vista ReadyBoost™ Device

- USB DiskOnModule can work as ReadyBoost™ Flash Device for Windows Vista with installation to USB port on the mother-board.
- USB DiskOnModule works Windows ReadyBoost™ device not only a removable disk but also a fixed disk.

3.5 Firmware Upgrade

- The firmware of USB DiskOnModule can not be upgraded in some case by customers, so please contact your nearest CSS office.

4. Flash Management Technology

In order to gain the best management for flash memory, CSS *DiskOnModule* supports an efficient and swift algorithm. Due to the life of flash memory is limited, CSS try to increase the life of our flash product through the following arrangement. There are some blocks are reserved in flash memory and these blocks would not be used in normal operation. Once any block is fail, one of these reserved blocks will replace it and the data of the fail block would be transferred to the reserved block for keeping the data's accuracy. After we used the above arrangement in flash memory, the life of the device will be longer than the device without it. When all of the reserved blocks have replaced the bad blocks, the device will be locked automatically to prevent programming, but the data can still be read out for back up.

Because the block of flash memory has a limited life, when the host writes data in the same address, CSS *DiskOnModule* does not to program data into the same physical place of the flash memory in purpose, our algorithm will get the data precisely when the host wants to read the data.

ECC (Error Correction Code) feature is also built in our hardware and firmware. ECC ensured the accuracy of the data, and decreased the effect of the cross talking on the bus.

5. Installation

5.1 Installation

- For Installation of USB DiskOnModule to your system, please follow up below steps;
 1. Make sure your computer has USB 10pins port on its mother-board.
 2. Plug the USB DiskOnModule carefully into USB port on your computer or host adapter.
 3. Check your system whether your operating system recognize USB DiskOnModule or not.

Notice: Please contact your closest CSS's office for verifying your other troubles.

6. Ordering Information

HBH41	-	001G	R	XX	0	0	00
Series	Range	Size	Green	Outline	Alternative	Level	Option

Table 4: HBH41 Ordering Information

Code	Definition	Description
HBH41	Series name	Product Series name, fixed
-	Temperature	“-”: Industrial, “W”: Wide temperature
001G	Memory size	512M: 512MB, 001G: 1GB, 002G: 2GB, 004G: 4GB, 008G: 8GB, 016G: 16GB
R	Green level	“R”: RoHS/PFOS
XX	Device outline	First digit shows pin count and connector type. Second digit defines performance and switch options. Please see the data sheet or contact CSS for details.
0	Alternative	Reserved
0	Level	Reserved
00	Option	Option for customization

7. Contact Information

CoreSolid Storage Corporation, a TDK-PQI storage business company, specializes in the design and marketing of SSD, DOM, and Industry CF products.

For further information, please reach us at the following contact information:

Global

- Tel: +886-2-66206168
- Sales: sales@coresolid-storage.com
- Customer Service: support@coresolid-storage.com

US specific

- Tel: +1-408-7257180
- Sales: sales@coresolid-storage.com
- Customer Service: support.us@coresolid-storage.com

China specific

- Tel: +86-10-82701610
- Sales: sales@coresolid-storage.com
- Customer Service: support.cn@coresolid-storage.com

Europe specific

- Tel: +886-2-66206168
- Sales: sales@coresolid-storage.com
- Customer Service: support.eu@coresolid-storage.com

Japan specific

- Tel: +81-47-3789423
- Sales: sales@coresolid-storage.com
- Customer Service: support.jp@coresolid-storage.com