

Titan SATA DOM Series

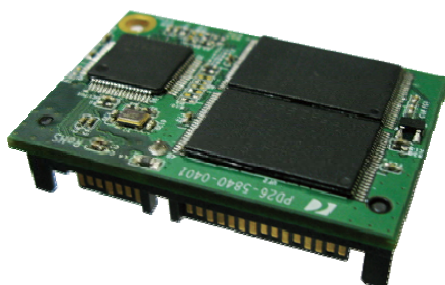

Table of Contents

1. Product Description 1

 1.1 Product Overview 1

 1.2 Product Features 1

 1.3 System Requirement 1

2. Specification 2

 2.1 Physical Specifications 2

 2.2 Electronic Specifications 3

 2.3 Performance Specifications 4

 2.4 Environmental Specifications 4

 2.5 Reliability Specifications 5

 2.6 Compliance Specifications 5

3. Function 6

 3.1 Pin Signal Assignment 6

 3.2 Support ATA Commands 7

 3.3 Firmware Upgrade 53

4. Installation 54

 4.1 Installation 54

 4.2 Partition 54

 4.3 Format 55

5. Troubleshooting 57

 5.1 Bios can not identify SATA DiskOnModule 57

 5.2 SATA DOM can not boot the system 57

6. Ordering Information 57

7. Contact Information 58

List of Figures

Figure 1: SATA DiskOnModule Overlook Diagram 2

Figure 2: SATA DOM Dimensions 2

Figure 3: SATA DiskOnModule Block Diagram 3

Figure 4: SATA Signal Connector..... 6

List of Tables

Table 1: SATA DiskOnModule Physical Dimension.....	2
Table 2 : Serial ATA connector pin definitions	6
Table 3: ATA Command Set.....	7
Table 4: Diagnostic Codes	13
Table 5: Identify Device Information	16
Table 6: Feature Supported.....	40
Table 7: Transfer mode values	40
Table 8: SATA DiskOnModule Ordering Information	57

Revision	Date	Major Changes
1.1	2008/12/30	<ol style="list-style-type: none"> 1. Correct SATA 1.0 to SATA 1.5Gb/s. 2. Update product model form SH11 to HSH11.
A.0	2009/3/17	<ol style="list-style-type: none"> 1. Add the notice in Section 2.6 2. Revise the notice in Section 5.2 3. Update contact information in Section 7

Copyright Information

Copyright © 2008, CoreSolid Storage Corporation. All rights reserved.

The information and specifications provided in this document should be used for comparative analysis and reference purposes. The content of this document is subject to change without prior notice.

1. Product Description

1.1 Product Overview

CoreSolid Storage's SATA DiskOnModule (DOM) is the storage device based on NAND flash memory technology. This product implements with single chip solution of TDK GBDriver series SATA flash controller. It is complied with Serial ATA standard interface and is suitable for data storage media and code storage device for embedded system and boot disk. By using **SATA DiskOnModule**, it is possible to operate good performance for the systems, which have SATA interface.

With small form factor, the applicable appliance can add or install SATA storage device on its Mother Board or Complete set.

● **Application Fields;**

- Industrial PC and Thin Client
- Game and Telecommunication Machine
- Ticketing, Examining, testing machine
- Army, Health and Production Equipment and Machine
- Other machines and Equipments with Serial ATA Interface Standard 1.5Gb/s

1.2 Product Features

- Small form factor with Serial ATA Standard Interface connector
- Single chip solution of TDK GBDriver SATA Flash memory controller
- Memory Capacities: 2GB ~ 8GB
- High reliability and robust design
- Noiseless and stable installation to system
- Operating voltage only 3.3V operation
- Standard Serial ATA Interface
- Support ATA SMART feature
- Support ATA Security mode feature
- Operating as Boot Disk
- Code Storage Device for Embedded Operating System

1.3 System Requirement

- The Host system which is connected to SATA DiskOnModule should meet system requirements at minimum;

1.3.1 Power Requirement

- Voltage: DC +3.3V \pm 5%

1.3.2 Operating System

- Windows 2000/XP/Vista
- Linux
- DOS
- WinXP Embedded
- WinCE

1.3.3 Interface

- Standard Serial ATA 1.5GB/s Interface

2. Specification

2.1 Physical Specifications

2.1.1 Overlook

The overlook views of SATA DiskOnModule are illustrated in Figure 1.

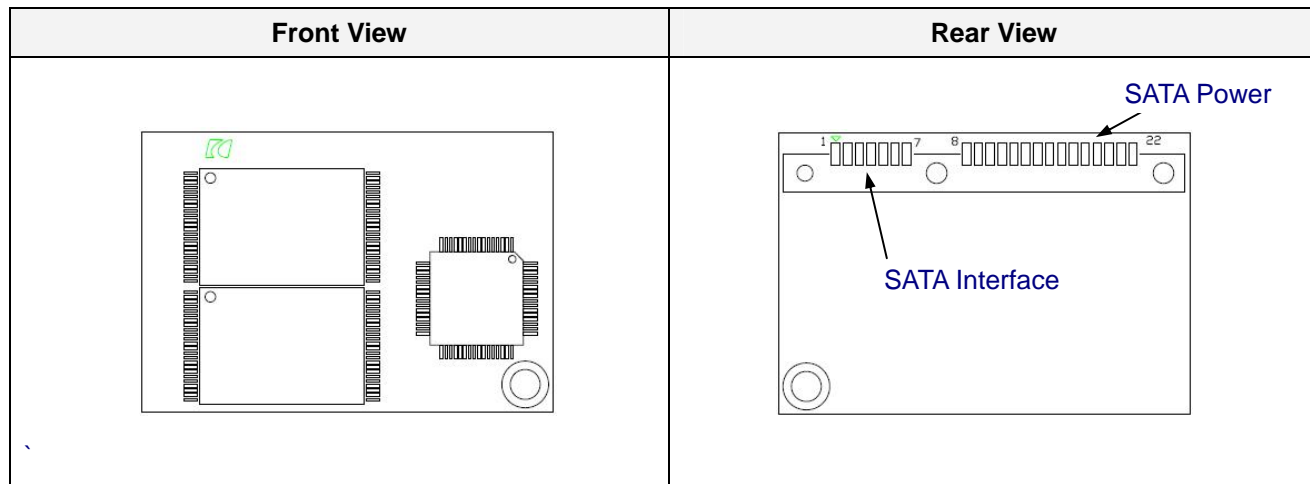

Figure 1: SATA DiskOnModule Overlook Diagram

2.1.2 Dimension

The Dimensions of SATA DiskOnModule are illustrated in Figure 2 and described in Table 1.

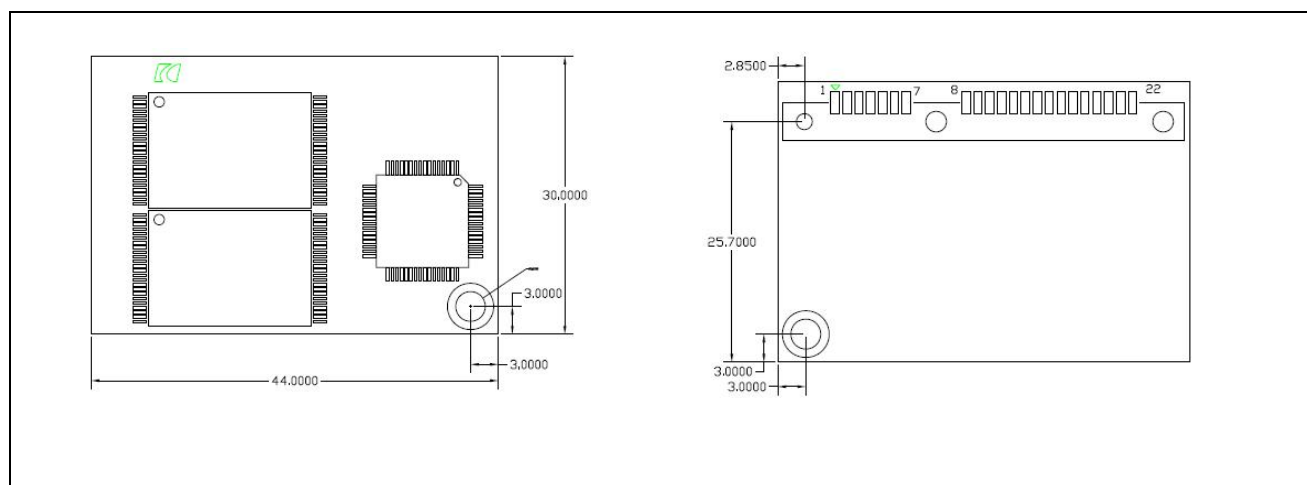

Figure 2: SATA DOM Dimensions

Table 1: SATA DiskOnModule Physical Dimension

Length	44 ± 0.15 mm
Width	30 ± 0.15 mm
Thickness	1.6 ± 0.15mm

2.1.3 Weight

- Weight: <8.5g

2.2 Electronic Specifications

2.2.1 Product Definition

SATA DiskOnModule is designed to operate and work as Data or Code Storage device by NAND Flash Memory and its Controller through Serial ATA Standard 1.5Gb/s Interface to Host Systems.

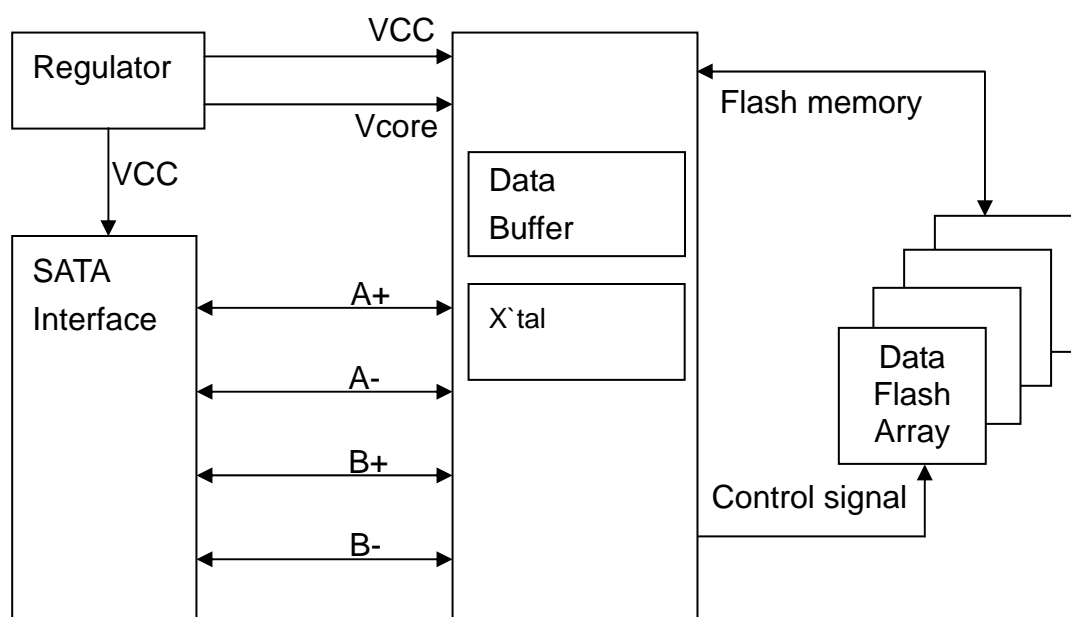

Figure 3: SATA DiskOnModule Block Diagram

2.2.2 Operating Voltage

- Voltage DC +3.3V \pm 5%

2.2.3 Capacity and Block Size information

- Capacity: 2GB ~ 8GB
- Sector Size: 512Bytes

2.2.4 Power Consumption

- DC Information
 - Read: <160mA
 - Write: <220mA
 - Stand-by: <140mA

※ Testing Platform;

Mother-Board: ASUS P5GC-FX, CPU: Core2Dual 1.60G, Chipset: Intel 945G+ICH7, Main Memory: DDR2-400 2GB
Operating System: WinXP, Test Program: DOMSV31

SATA DiskOnModule

2.3 Performance Specifications

2.3.1 Modes

- SATA 1.5Gb/s
- PIO mode 4
- MW DMA 2
- Ultra DMA 2

2.3.2 Access Time

- SATA DiskOnModule's maximum access time is about 0.3msec.

※ Testing Platform

Testing S/W: HD Tune 2.53, Testing OS: WinXP

Mother-Board: ASUS P5GC-FX, CPU: Core2Dual 1.60G, Chipset: Intel 945G+ICH7, Main Memory: DDR2-400 2GB

Testing base: Time required Between Host to Device

2.3.3 Seek Time

- SATA DiskOnModule has no seek time by being based on Flash Memory technology.

2.3.4 Mount Time

The Mount Time for initializing and mounting SATA DiskOnModule is different by depending on Operating System and testing Platform.

2.3.5 Data Transfer Time

- Sequential Read: up to 20MB/sec
- Sequential Write: up to 14MB/sec

※ Test Platform: Average Value based on Serial ATA 1.5Gb/s Mode

Mother-Board: ASUS P5GC-FX, CPU: Core2Dual 1.60G, Chipset: Intel 945G+ICH7, Main Memory: DDR2-400 2GB

Testing Software: HD Bench 3.4 Testing OS: Windows XP

Notice

The value is various bases on the testing platform.

2.3.6 Data Retention

- 10 years without requiring power support

Notice

The Value of Data Retention is various bases on the type and manufacturer of Flash Memory

2.3.7 Read/Write Cycle

- Read/ Write: 2,000,000 times

2.4 Environmental Specifications

2.4.1 Temperature

- Operating Temperature: -20°C to +85°C for extended temperature model.
- Storage Temperature: -55°C to +95°C.

2.4.2 Humidity

- Operating Humidity: 10% to 95%
- Non-Operating Humidity: 10% to 95% (with no condensation relative humidity)

2.4.3 Bare Drop test

- Bare Drop Testing (Free Fell) at 75cm: Pass
Front/Rear/Right/Left/Top/Bottom Side

SATA DiskOnModule

2.4.4 Vibration

- Sine Vibration Test (Non-Operation): 15G
Frequency: 10 ~ 500Hz, Dwell Time (min): 30min per Axis (X, Y, Z)
- Random Vibration Test (Operation) : 6Grms
Frequency: 10 ~ 500Hz, PSD (G^2/Hz): 0.01 ~ 0.08, Dwell time (min): 30min per Axis (X, Y, Z)

2.5 Reliability Specifications

2.5.1 ECC/EDC (Error Correction Code/Error Detection Code)

- 1bytes data by 128bytes will be corrected.

2.5.2 Read and Write/Erase Cycle

- Read: No Limitation
- Write/Erase: 2,000,000 times

Notice: The Value of Write/Erase Cycle is various bases on the type and manufacturer of NAND Flash Memory.

2.5.3 MTBF (Mean Time Between Failure)

- 2,000,000 hours

2.6 Compliance Specifications

- CE
- FCC

Notice: Please contact your closest CSS office for other certificate information.

3. Function

3.1 Pin Signal Assignment

- The signals assigned for Serial ATA applications are described in Table 2

Table 2 : Serial ATA connector pin definitions

Segment	Pin No	Function	Definition
Signal	S1	Gnd	
	S2	A+	Differential signal pair A from Phy
	S3	A-	
	S4	Gnd	
	S5	B-	Differential signal pair B from Phy
	S6	B+	
	S7	Gnd	

Key and spacing separate signal and power segments

Power	P1	V33	3.3V power
	P2	V33	3.3V power
	P3	V33	3.3V power
	P4	Gnd	Ground
	P5	Gnd	Ground
	P6	Gnd	Ground
	P7	V5	NC
	P8	V5	NC
	P9	V5	NC
	P10	Gnd	Ground
	P11	Reserved	NC
	P12	Gnd	Ground
	P13	V12	NC
	P14	V12	NC
	P15	V12	NC

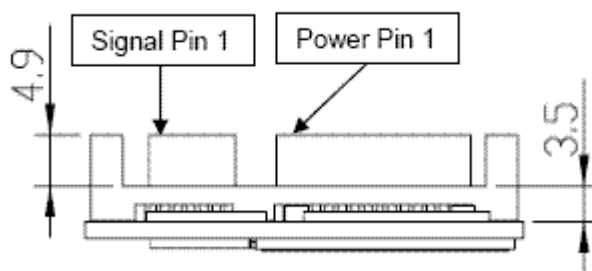

Figure 4: SATA Signal Connector

Notice All pins are a 1.27 mm (0.050") pitch.

3.2 Support ATA Commands

- **ATA Command Set**

- ATA Command Set summarizes the ATA command set with the paragraphs that follow describing the individual commands and the task file for each.

Table 3: ATA Command Set

COMMAND	Code
CFA ERASE SECTORS	C0h
CFA REQUEST EXTENDED ERROR CODE	03h
CFA TRANSLATE SECTOR	87h
CFA WRITE MULTIPLE WITHOUT ERASE	CDh
CFA WRITE SECTORS WITHOUT ERASE	38h
Check Power Mode	E5h or 98h
Execute Drive Diagnostic	90h
FLUSH CACHE	E7h
FORMAT TRACK	50h
Identify Device	ECh
Idle	E3h or 97h
Idle Immediate	E1h or 95h
Initialize Drive Parameters	91h
NOP	00h
READ BUFFER	E4h
Read DMA	C8h or C9h
READ LONG SECTOR	22h,23h
Read Multiple	C4h
Read Sector(s)	20h or 21h
Read Verify Sector(s)	40h or 41h
Recalibrate	1Xh
SECURITY DISABLE PASSWORD	F6h
SECURITY ERASE PREPARE	F3h
SECURITY ERASE UNIT	F4h
SECURITY FREEZE LOCK	F5h
SECURITY SET PASSWORD	F1h
SECURITY UNLOCK	F2h
Seek	7Xh
Set Features	EFh
Set Multiple Mode	C6h
Sleep	E6h or 99h
SMART DISABLE OPERATIONS	B0h
SMART ENABLE/DISABLE ATTRIBUTE AUTOSAVE	B0h
SMART ENABLE OPERATIONS	B0h
SMART READ DATA	B0h
SMART RETURN STATUS	B0h

COMMAND	Code
Standby	E2h or 96h
Standby Immediate	E0h or 94h
WRITE BUFFER	E8h
Write DMA	CAh or CBh
WRITE LONG SECTOR	32h or 33h
Write Multiple	C5h
Write Sector(s)	30h or 31h

(1) CFA ERASE SECTORS (C0h)

When this command is received, the flash memory corresponding to the specified sector addressed is erased units of physical blocks. If the last sector is exceeded while erasing data, after the data in the last sector is erased, the command is aborted with an address overflow. This command operates regardless of the CFA feature set support(value of bit 2 of IDENTIFY DEVICE command parameter information Word83).

[Memorizing the Erased Range]

Erase operation unit is a physical block of NAND Flash memory. Physical block size is 512 sectors(SLC) or 1024sectors(MLC). This command can't cover the whole page of a physical block, so erase can't execute one command. The address range specified with this command will be memorized. If a physical block which was not covered by the address range specified with the previous command is covered by the address range specified with the next command, this block will be erased.

If the newly specified address range succeeds or overlaps the memorized address range, the address range covering the two address ranges is considered as a new address range to be memorized. If the new address range specified with this command does not succeed a saved address range, then when a write related command is issued, or when a reset operation(power-on reset, hardware reset, or each software reset) is performed, or when it goes into vendor mode, the memorized address range will be cleared.

Inputs

Register	7	6	5	4	3	2	1	0
Feature	na							
Sector Count	Sector Count							
Sector Number	Sector Number or LBA [7:0]							
Cylinder Low	Cylinder Low or LBA [15:8]							
Cylinder High	Cylinder High or LBA [23:16]							
Device/Head	na	LBA	na	0	Head or LBA [27:24]			
Command	98h or E5h							

Sector Count register: The number of sectors to be erased (256 sectors in the case of 00h)

Sector Number register: Starting sector address to be erased (CHS: Sector address/LBA: LBA [7:0])

Cylinder Low register: Starting sector address to be erased (CHS: Lower cylinder address/LBA: LBA [15:8])

Cylinder High register: Starting sector address to be erased (CHS: Upper cylinder address/LBA: LBA [23:16])

Device/Head register: Starting sector address to be erased (CHS: Head address/LBA: LBA [27:24]), Drive No.(Fixed 0).LBA flag

Normal outputs

Register	7	6	5	4	3	2	1	0
Error	Na							
Sector Count	00h							
Sector Number	Sector Number or LBA [7:0]							
Cylinder Low	Cylinder Low or LBA [15:8]							
Cylinder High	Cylinder High or LBA [23:16]							
Device/Head	na	LBA	na	0	Head or LBA [27:24]			
Status	BSY	DRAY	DWF	DSC	DRQ	CORR	na	ERR

Status register: 50h

Sector Count register: 00h

Sector Number register: Last erased sector address (CHS: Sector address/LBA: LBA [7:0])

Cylinder Low register: Last erased sector address (CHS: Lower cylinder address/LBA: LBA [15:8])

Cylinder High register: Last erased sector address (CHS: Upper cylinder address/LBA: LBA [23:16])

Device/Head register: Last erased sector address (CHS: Head address/LBA: LBA [27:24]), Drive No.(Fixed 0), LBA flag

(2) CFA REQUEST EXTENDED ERROR CODE(03h)

This command is used to obtain detailed information on an error from the preceding command and return the information described below. After this command is received, the error information on the preceding command is set into the Error register. If any reset (reset of power-on, hardware, or software reset) is done between the preceding command and this command, the values returned by this command are not valid. This command operates regardless of the CFA feature set support (value of bit 2 of IDENTIFY DEVICE command parameter information Word83). This command is no error termination.

Inputs

Register	7	6	5	4	3	2	1	0
Feature	na							
Sector Count	na							
Sector Number	na							
Cylinder Low	na							
Cylinder High	na							
Device/Head	na			0	na			
Command	03h							

Device/Head register: Drive No.(Fixed 0).

Normal outputs

Register	7	6	5	4	3	2	1	0
Error	Extended error code							
Sector Count	na							
Sector Number	na							
Cylinder Low	na							
Cylinder High	na							
Device/Head	na			0	na			
Status	BSY	DRAY	DWF	DSC	DRQ	CORR	na	ERR

Status register: 50h(10h when DRDY is cleared to 0)

Error register See the codes shown in the above table.

(3) CFA TRANSLATE SECTOR(87h)

This command is used to provide information on the erased state and the writing times of a specified sector to the host. With regard to the information returned by this device, see the TRANSLATE SECTOR information described below.

This command operates regardless of the CFA feature set support(value of bit 2 of IDENTIFY DEVICE command parameter information Word83).

Byte	Description	
	CHS	LBA
00h-01h	Cylinder MSB(00), Cylinder LSB(01)	Na
02h	Head	Na
03h	Sector	Na
04h-06h	LBA MBS(04)–LBA LSB(06)	
07h-12h	Reserved(00h)	
11h	Erased Flag(00h fixed)	
14h-17h	Reserved(00h)	
18h-1Ah	Hot count(00 00 00h fixed)	
1Bh-1FFh	Reserved(00h)	

Erased Flag

This device always return 00h(not erased).

Hot count

This device always return 00 00 00h

LBA

The data of 24 bits except MSB of LBA address will be set.

[CHS Mode]

Sector address information specified by the task file register is set in each byte from 00h to 03h, and the address of LBA calculated from CHS is set from 04h to 06h.

[LBA Mode]

Byte from 00h to 03h are undefine. Sector address information specified by the task file register is set from 04h to 06h.

Inputs

Register	7	6	5	4	3	2	1	0
Feature	na							
Sector Count	na							
Sector Number	Sector Number or LBA [7:0]							
Cylinder Low	Cylinder Low or LBA [15:8]							
Cylinder High	Cylinder High or LBA [23:16]							
Device/Head	na	LBA	na	0	Head or LBA [27:24]			
Command	87h							

Sector Number register: Specified sector address (CHS: Sector address/LBA: LBA [7:0])

Cylinder Low register: Specified sector address (CHS: Lower cylinder address/LBA: LBA [15:8])

Cylinder High register: Specified sector address (CHS: Upper cylinder address/LBA: LBA [23:16])

Device/Head register: Specified sector address (CHS: Head address/LBA: LBA [27:24]), Drive No.(Fixed 0), LBA flag

Normal outputs

Register	7	6	5	4	3	2	1	0
Error	na							
Sector Count	na							
Sector Number	Sector Number or LBA [7:0]							
Cylinder Low	Cylinder Low or LBA [15:8]							
Cylinder High	Cylinder High or LBA [23:16]							
Device/Head	na	LBA	na	0	Head or LBA [27:24]			
Status	BSY	DRAY	DWF	DSC	DRQ	CORR	na	ERR

Status register: 50h (10h when DRDY is cleared to 0)

(4) CFA WRITE MULTIPLE WITHOUT ERASE(CDh)

This command is treated in the same way as the WRITE MULTIPLE command. This command operates regardless of “the CFA feature set support” (value of bit 2 of IDENTIFY DEVICE command parameter information Word83).

Inputs

Register	7	6	5	4	3	2	1	0
Feature	na							
Sector Count	Sector Count							
Sector Number	Sector Number or LBA [7:0]							
Cylinder Low	Cylinder Low or LBA [15:8]							
Cylinder High	Cylinder High or LBA [23:16]							
Device/Head	na	LBA	na	0	Head or LBA [27:24]			
Command	CDh							

Sector Count register: The number of sectors to be written (256 sectors are transferred in the case of 00h)

Sector Number register: Starting sector address to be written (CHS: Sector address/LBA: LBA [7:0])

Cylinder Low register: Starting sector address to be written (CHS: Lower cylinder address/LBA: LBA [15:8])

Cylinder High register: Starting sector address to be written (CHS: Upper cylinder address/LBA: LBA [23:16])

Device/Head register: Starting sector address to be written (CHS: Head address/LBA: LBA [27:24]), Drive No.(Fixed 0),LBA flag

Normal outputs

Register	7	6	5	4	3	2	1	0
Error	na							
Sector Count	na							
Sector Number	Sector Number or LBA [7:0]							
Cylinder Low	Cylinder Low or LBA [15:8]							
Cylinder High	Cylinder High or LBA [23:16]							
Device/Head	na	LBA	na	0	Head or LBA [27:24]			
Status	BSY	DRAY	DWF	DSC	DRQ	CORR	na	ERR

Status register: 50h

Sector Count register: 00h

Sector Number register: Last written sector address (CHS: Sector address/LBA: LBA [7:0])

Cylinder Low register: Last written sector address (CHS: Lower cylinder address/LBA: LBA [15:8])

Cylinder High register: Last written sector address (CHS: Upper cylinder address/LBA: LBA [23:16])

Device/Head register: Last written sector address (CHS: Head address/LBA: LBA [27:24]), Drive No.(Fixed 0), LBA flag

(5) CFA WRITE SECTORS WITHOUT ERASE(38h)

This command is treated in the same way as the WRITE SECTOR(S) command. This command operates regardless of “the CFA feature set support” (value of bit 2 of IDENTIFY DEVICE command parameter information Word83).

Inputs

Register	7	6	5	4	3	2	1	0
Feature	na							
Sector Count	Sector Count							
Sector Number	Sector Number or LBA [7:0]							
Cylinder Low	Cylinder Low or LBA [15:8]							
Cylinder High	Cylinder High or LBA [23:16]							
Device/Head	na	LBA	na	0	Head or LBA [27:24]			
Command	38h							

Sector Count register: The number of sectors to be written (256 sectors are transferred in the case of 00h)

Sector Number register: Starting sector address to be written (CHS: Sector address/LBA: LBA [7:0])

Cylinder Low register: Starting sector address to be written (CHS: Lower cylinder address/LBA: LBA [15:8])

Cylinder High register: Starting sector address to be written (CHS: Upper cylinder address/LBA: LBA [23:16])

Device/Head register: Starting sector address to be written (CHS: Head address/LBA: LBA [27:24]), Drive No.(Fixed 0), LBA flag

Normal outputs

Register	7	6	5	4	3	2	1	0
Error	na							
Sector Count	na							
Sector Number	Sector Number or LBA [7:0]							
Cylinder Low	Cylinder Low or LBA [15:8]							
Cylinder High	Cylinder High or LBA [23:16]							
Device/Head	na	LBA	na	0	Head or LBA [27:24]			
Status	BSY	DRAY	DWF	DSC	DRQ	CORR	na	ERR

Status register: 50h

Sector Count register: 00h

Sector Number register: Last written sector address (CHS: Sector address/LBA: LBA [7:0])

Cylinder Low register: Last written sector address (CHS: Lower cylinder address/LBA: LBA [15:8])

Cylinder High register: Last written sector address (CHS: Upper cylinder address/LBA: LBA [23:16])

Device/Head register: Last written sector address (CHS: Head address/LBA: LBA [27:24]), Drive No.(Fixed 0)., LBA flag

(6) CHCKE POWER MODE(98h or E5h)

This command is used to return the present power mode. Whether the automatic power down is enabled or disabled in this device is returned. If the automatic power down mode is enabled, 00h is set to the Sector Count register. If the automatic power down mode is disabled, FFh is set to the Sector Count register. The execution of this command does not affect the operation mode of the power management function. This command is no error termination.

Inputs

Register	7	6	5	4	3	2	1	0
Feature	na							
Sector Count	na							
Sector Number	na							
Cylinder Low	na							
Cylinder High	na							
Device/Head	na			0	na			
Command	98h or E5h							

Device/Head register: Drive No.(Fixed 0).

Normal outputs

Register	7	6	5	4	3	2	1	0
Error	na							
Sector Count	result							
Sector Number	na							
Cylinder Low	na							
Cylinder High	na							
Device/Head	na			0	na			
Status	BSY	DRAY	DWF	DSC	DRQ	CORR	na	ERR

Status register: 50h(10h when DRDY is cleared to 0)

Sector Count register: 00h(In the case that automatic power down is enabled)

FFh(In the case that automatic power down is disabled)

(7) EXECUTE DEVICE DIAGNOSTIC(90h)

This command is used to check whether or not there is a fatal error in this device and return Diagnostic Codes as shown in the table below to the host. This command is no error termination.

Table 4: Diagnostic Codes

Code	Error Type
01h	No error
02h	Fatal error found

Inputs

Register	7	6	5	4	3	2	1	0
Feature	na							
Sector Count	na							
Sector Number	na							
Cylinder Low	na							
Cylinder High	na							
Device/Head	na							
Command	90h							

D4 (Device No.) of the Device/Head register is not evaluated. This command is executed for both the master and slaves.

Normal outputs

Register	7	6	5	4	3	2	1	0
Error	Diagnostic code							
Sector Count	01h							
Sector Number	01h							
Cylinder Low	00h							
Cylinder High	00h							
Device/Head	A0h							
Status	BSY	DRAY	DWF	DSC	DRQ	CORR	na	ERR

Status register: 50h(10h when DRDY is cleared to 0)

Error register: See the codes shown in the above table.

(8) FLUSH CACHE (E7h)

Although this command is usually used to write data in the cache to the flash, nothing is executed for this command. It operates regardless of the state of the support of the FLUSH CACHE command (value of bit 12 of Word83 of IDENTIFY DEVICE command parameter information).

Inputs

Register	7	6	5	4	3	2	1	0
Feature	na							
Sector Count	na							
Sector Number	na							
Cylinder Low	na							
Cylinder High	na							
Device/Head	na			0	na			
Command	E7h							

Device/Head register: Drive No.(Fixed 0).

Normal outputs

Register	7	6	5	4	3	2	1	0
Error	na							
Sector Count	na							
Sector Number	na							
Cylinder Low	na							
Cylinder High	na							
Device/Head	na			0	na			
Status	BSY	DRAY	DWF	DSC	DRQ	CORR	na	ERR

Status register: 50h(10h when DRDY is cleared to 0)

(9) FORMAT TRACK (50h)

Nothing is executed in this command though this command is defined to initialize the specified sector by the specified data. The command protocol is the 1-sector PIO OUT protocol (command related to the write operation). This command is not supported by the ATA -4 and subsequent versions of the ATA standard. Also, the CFA standard does not recommend the use of this command. This command is no error termination.

Inputs

Register	7	6	5	4	3	2	1	0
Feature	na							
Sector Count	Sector Count							
Sector Number	Sector Number or LBA [7:0]							
Cylinder Low	Cylinder Low or LBA [15:8]							
Cylinder High	Cylinder High or LBA [23:16]							
Device/Head	na	LBA	na	0	Head or LBA [27:24]			
Command	50h							

Sector Count register: The number of sectors to be written (256 sectors are transferred in the case of 00h)

Sector Number register: Starting sector address to be written (CHS: Sector address/LBA: LBA [7:0])

Cylinder Low register: Starting sector address to be written (CHS: Lower cylinder address/LBA: LBA [15:8])

Cylinder High register: Starting sector address to be written (CHS: Upper cylinder address/LBA: LBA [23:16])

Device/Head register: Starting sector address to be written (CHS: Head address/LBA: LBA [27:24]), Drive No.(Fixed 0), LBA flag

Normal outputs

Register	7	6	5	4	3	2	1	0
Error	na							
Sector Count	00h							
Sector Number	Sector Number or LBA [7:0]							
Cylinder Low	Cylinder Low or LBA [15:8]							
Cylinder High	Cylinder High or LBA [23:16]							
Device/Head	na	LBA	na	0	Head or LBA [27:24]			
Status	BSY	DRAY	DWF	DSC	DRQ	CORR	na	ERR

Status register: 50h (10h when DRDY is cleared to 0)

Sector Count register: 00h

Sector Number register: Last formatted sector address (CHS: Sector address/LBA: LBA [7:0])

Cylinder Low register: Last formatted sector address (CHS: Lower cylinder address/LBA: LBA [15:8])

Cylinder High register: Last formatted sector address (CHS: Upper cylinder address/LBA: LBA [23:16])

Device/Head register: Last formatted sector address (CHS: Head address/LBA: LBA [27:24]), Drive No.(Fixed 0), LBA flag

(10) IDENTIFY DEVICE (ECh)

This command is used to get the drive parameter information. This device returns 1-sector data to the host. With regard to the returned values of the drive parameter information, refer to " IDENTIFY DEVICE information specification". This command is no error termination.

Inputs

Register	7	6	5	4	3	2	1	0
Feature	na							
Sector Count	na							
Sector Number	na							
Cylinder Low	na							
Cylinder High	na							
Device/Head	na			0	na			
Command	ECh							

Device/Head register: Drive No.(Fixed 0).

Normal outputs

Register	7	6	5	4	3	2	1	0
Error	na							
Sector Count	na							
Sector Number	na							
Cylinder Low	na							
Cylinder High	na							
Device/Head	na			0	na			
Status	BSY	DRAY	DWF	DSC	DRQ	CORR	na	ERR

Status register: 50h(10h when DRDY is cleared to 0)

Among the return values of the IDENTIFY DEVICE command, you can customize those with the asterisk ("*") in the IDENTIFY DEVICE information specifications in the table below. With regard to the customized values, refer to the values in the table below. Regarding how to set up the IDENTIFY DEVICE information, see the vendor-specific commands specification. If using the latest standard, there might be a problem in the compatibility with the existing host system. Be sure to verify the compatibility with the host system to be used when you set up this parameter.

Table 5: Identify Device Information

Word Address	Total Bytes	Availability	Data Field Type Information
0	2	*	General configuration
1	2	-	Default number of cylinders. Please refer to Drive Parameter information.(ATA7 is obsolete)
2	2	*	Specific configuration
3	2	-	Default number of heads. Please refer to Drive Parameter information. (ATA7 is obsolete)
4	2	-	0000h: Retired
5	2	*	Retired
6	2	-	Number of sectors per track. Please refer to Drive Parameter information. (ATA7 is obsolete)
7-8	4	-	Total number of sectors (See Drive Parameter Specifications.)
9	2	-	0000h: Obsolete
10-19	20	*	Serial number (20 ASCII characters)
20	2	*	Retired
21	2	*	Retired
22	2	*	Number of vendor specific bytes available on READ/WRITE LONG cmds
23-26	8	-	Firmware revision (8 ASCII characters)

Word Address	Total Bytes	Availability	Data Field Type Information
27-46	40	*	Model number (40 ASCII characters)
47	2	*	15-8 80h: Fixed
			7-0 01h: Maximum number of sectors that shall be transferred per interrupt on READ/WRITE MULTIPLE commands.(Fixed to 01h)
48	2	-	0000h: Reserved
49	2	*	Capabilities 15-14 Reserved for the IDENTIFY PACKET DEVICE command. 13 1 = Standby timer values as specified in this standard are supported 0 = Standby timer values shall be managed by the device 12 Reserved for the IDENTIFY PACKET DEVICE command. 11 1 = IORDY supported 0 = IORDY may be supported 10 1 = IORDY may be disabled 9 1 = LBA supported 8 1 = DMA supported. 7-0 Retired
50	2	*	Capabilities 15 Shall be cleared to zero. 14 Shall be set to one. 13-2 Reserved. 1 Obsolete 0 Shall be set to one to indicate a device specific Standby timer value minimum.
51	2	-	0200h: 15-8 PIO data transfer mode number 7-0 retired .(ATA7 is obsolete)
52	2	-	0000h: Reserved
53	2	*	15-3 Reserved 2 1=the fields reported in word 88 are valid 0=the fields reported in word 88 are not valid 1 1=the fields reported in words 64-70 are valid 0=the fields reported in words 64-70 are not valid 0 1=the fields reported in words 54-58 are valid 0=the fields reported in words 54-58 may be valid
54	2	-	Number of current logical cylinders. .(ATA7 is obsolete)
55	2	-	Number of current logical heads..(ATA7 is obsolete)
56	2	-	Number of current logical sectors per track. .(ATA7 is obsolete)
57-58	4	-	Current capacity in sectors. .(ATA7 is obsolete)
59	2	-	01h: 15-9 Reserved
		-	8 1=Multiple sector setting is valid 7-0 xxh=Current setting for number of sectors that shall be transferred per interrupt on R/W Multiple command
60-61	4	-	Total number of user addressable sectors

Word Address	Total Bytes	Availability	Data Field Type Information
62	2	-	0000h: Reserved
63	2	-	15-11 Reserved 10 1 = Multiword DMA mode 2 is selected 0 = Multiword DMA mode 2 is not selected 9 1 = Multiword DMA mode 1 is selected 0 = Multiword DMA mode 1 is not selected 8 1 = Multiword DMA mode 0 is selected 0 = Multiword DMA mode 0 is not selected
		*	7-3 Reserved 2 1 = Multiword DMA mode 2 and below are supported 1 1 = Multiword DMA mode 1 and below are 0 1 = Multiword DMA mode 0 is supported
64	2	*	15-8 Reserved 7-0 PIO modes supported
65	2	*	Minimum Multiword DMA transfer cycle time per word
66	2	*	Manufacturer's recommended Multiword DMA transfer cycle time
67	2	*	Minimum PIO transfer cycle time without flow control
68	2	*	Minimum PIO transfer cycle time with IORDY flow control
69-74	12	-	0000h: Reserved
75	2	-	0000h: Queue depth.(not supported)
76	2	-	0202h: Serial ATA capabilities 15-13 Reserved 12 Supports Native Command Queuing priority information 11 Supports Unload while NCQ commands outstanding 10 Supports Phy event counters 9 Supports receipt of host-initiated interface power management requests 8 Supports Native Command Queuing 7-3 Reserved for future Serial ATA signaling speed grades 2 1 = Supports Serial ATA Gen2 signaling speed (3.0 Gbps) 1 1 = Supports Serial ATA Gen1 signaling speed (1.5 Gbps) 0 Shall be cleared to zero
		*	
77	2	-	0000h: Reserved for future Serial ATA definition
78	2	-	0008h: Serial ATA features supported 15-7 Reserved 6 1 = Supports software settings preservation 5 Reserved 4 1 = Supports in-order data delivery 3 1 = Device supports initiating interface power management 2 1 = Supports DMA Setup Auto-Activate optimization 1 1 = Supports non-zero buffer offsets in DMA Setup FIS 0 Shall be cleared to zero
		*	
79	2	-	0000h: Serial ATA features enabled

Word Address	Total Bytes	Availability	Data Field Type Information
			bit 3 is variable. 15-7 Reserved 6 1 = Software settings preservation enabled 5 Reserved 4 1 = In-order data delivery enabled 3 1 = Device initiating interface power management enabled 2 1 = DMA Setup Auto-Activate optimization enabled 1 1 = Non-zero buffer offsets in DMA Setup FIS enabled 0 Shall be cleared to zero
80	2	*	Major version number 0000h or FFFFh = device does not report version 15-8 Reserved 7 1 = supports ATA/ATAPI-7 6 1 = supports ATA/ATAPI-6 5 1 = supports ATA/ATAPI-5 4 1 = supports ATA/ATAPI-4 3 Obsolete 2 Obsolete 1 Obsolete 0 Reserved
81	2	*	Minor version number 0000h or FFFFh = device does not report version 0017h: ATA-4 revision 17 0013h: ATA-5 revision 3 0019h: ATA-6 revision 3a 0021h: ATA-7 revision 4a For more information, please refer to ATA standards.
82	2	*	Command set supported. 15 Obsolete 14 1 = NOP command supported 13 1 = READ BUFFER command supported 12 1 = WRITE BUFFER command supported 11 Obsolete 10 1 = Host Protected Area feature set supported 9 1 = DEVICE RESET command supported 8 1 = SERVICE interrupt supported 7 1 = release interrupt supported 6 1 = look-ahead supported 5 1 = write cache supported 4 Shall be cleared to zero to indicate that the PACKET Command feature set is not

Word Address	Total Bytes	Availability	Data Field Type Information
			supported. 3 1 = mandatory Power Management feature set supported 2 1 = Removable Media feature set supported 1 1 = Security Mode feature set supported 0 1 = SMART feature set supported
83	2	*	Command sets supported. 15 Shall be cleared to zero 14 Shall be set to one 13 1 = FLUSH CACHE EXT command supported 12 1 = mandatory FLUSH CACHE command supported 11 1 = Device Configuration Overlay feature set supported 10 1 = 48-bit Address feature set supported 9 1 = Automatic Acoustic Management feature set supported 8 1 = SET MAX security extension supported 7 See Address Offset Reserved Area Boot, INCITS TR27:2001 6 1 = SET FEATURES subcommand required to spinup after power-up 5 1 = Power-Up In Standby feature set supported 4 1 = Removable Media Status Notification feature set supported 3 1 = Advanced Power Management feature set supported 2 1 = CFA feature set supported 1 1 = READ/WRITE DMA QUEUED supported 0 1 = DOWNLOAD MICROCODE command supported
84	2	*	Command set/feature supported extension. 15 Shall be cleared to zero 14 Shall be set to one 13 1 = IDLE IMMEDIATE with UNLOAD FEATURE supported 12 Reserved for technical report 11 Reserved for technical report 10 1 = URG bit supported for WRITE STREAM DMA EXT and WRITE TREAM EXT 9 1 = URG bit supported for READ STREAM DMA EXT and READ STREAM EXT 8 1 = 64-bit World wide name supported 7 1 = WRITE DMA QUEUED FUA EXT command supported 6 1 = WRITE DMA FUA EXT and WRITE MULTIPLE FUA EXT commands supported 5 1 = General Purpose Logging feature set supported 4 1 = Streaming feature set supported 3 1 = Media Card Pass Through Command feature set supported 2 1 = Media serial number supported 1 1 = SMART self-test supported 0 1 = SMART error logging supported
85	2	*	Command set/feature enabled.

Word Address	Total Bytes	Availability	Data Field Type Information
			bit 5, bit 1, bit 0 is variable. 15 Obsolete 14 1 = NOP command enabled 13 1 = READ BUFFER command enabled 12 1 = WRITE BUFFER command enabled 11 Obsolete 10 1 = Host Protected Area feature set enabled 9 1 = DEVICE RESET command enabled 8 1 = SERVICE interrupt enabled 7 1 = release interrupt enabled 6 1 = look-ahead enabled 5 1 = write cache enabled 4 Shall be cleared to zero to indicate that the PACKET Command feature set is not supported. 3 1 = Power Management feature set enabled 2 1 = Removable Media feature set enabled 1 1 = Security Mode feature set enabled 0 1 = SMART feature set enabled
86	2	*	Command set/feature enabled. 15-14 Reserved 13 1 = FLUSH CACHE EXT command supported 12 1 = FLUSH CACHE command supported 11 1 = Device Configuration Overlay supported 10 1 = 48-bit Address features set supported 9 1 = Automatic Acoustic Management feature set enabled 8 1 = SET MAX security extension enabled by SET MAX SET PASSWORD 7 See Address Offset Reserved Area Boot, INCITS TR27:2001 6 1 = SET FEATURES subcommand required to spin-up after power-up 5 1 = Power-Up In Standby feature set enabled 4 1 = Removable Media Status Notification feature set enabled 3 1 = Advanced Power Management feature set enabled 2 1 = CFA feature set enabled 1 1 = READ/WRITE DMA QUEUED command supported 0 1 = DOWNLOAD MICROCODE command supported
87	2	*	Command set/feature default. 15 Shall be cleared to zero 14 Shall be set to one 13 1 = IDLE IMMEDIATE with UNLOAD FEATURE supported 12 Reserved for technical report-

Word Address	Total Bytes	Availability	Data Field Type Information
			11 Reserved for technical report- 10 1 = URG bit supported for WRITE STREAM DMA EXT and WRITE STREAM EXT 9 1 = URG bit supported for READ STREAM DMA EXT and READ STREAM EXT 8 1 = 64 bit World wide name supported 7 1 = WRITE DMA QUEUED FUA EXT command supported 6 1 = WRITE DMA FUA EXT and WRITE MULTIPLE FUA EXT commands supported 5 1 = General Purpose Logging feature set supported 4 1 = Valid CONFIGURE STREAM command has been executed 3 1 = Media Card Pass Through Command feature set enabled 2 1 = Media serial number is valid 1 1 = SMART self-test supported 0 1 = SMART error logging supported
88	2	-	15 Reserved 14 1 = Ultra DMA mode 6 is selected 0 = Ultra DMA mode 6 is not selected 13 1 = Ultra DMA mode 5 is selected 0 = Ultra DMA mode 5 is not selected 12 1 = Ultra DMA mode 4 is selected 0 = Ultra DMA mode 4 is not selected 11 1 = Ultra DMA mode 3 is selected 0 = Ultra DMA mode 3 is not selected 10 1 = Ultra DMA mode 2 is selected 0 = Ultra DMA mode 2 is not selected 9 1 = Ultra DMA mode 1 is selected 0 = Ultra DMA mode 1 is not selected 8 1 = Ultra DMA mode 0 is selected 0 = Ultra DMA mode 0 is not selected
		*	7 Reserved 6 1 = Ultra DMA mode 6 and below are supported 5 1 = Ultra DMA mode 5 and below are supported 4 1 = Ultra DMA mode 4 and below are supported 3 1 = Ultra DMA mode 3 and below are supported 2 1 = Ultra DMA mode 2 and below are supported 1 1 = Ultra DMA mode 1 and below are supported 0 1 = Ultra DMA mode 0 is supported
89	2	-	0000h: Time required for security erase unit completion
90	2	-	0000h: Time required for Enhanced security erase completion
91	2	-	0000h: Current advanced power management value
92	2	-	Master Password Revision Code
93	2	-	Non-definite value : Hardware Configuration Test Result(Not supported)
94-118	50	-	0000h: Not supported
119-126	16	-	0000h: Reserved

Word Address	Total Bytes	Availability	Data Field Type Information
127	2	-	0000h: Removable Media Status Notification feature set support Removable Media Status Notification feature set not supported
128	2	*	Security status 15-9 Reserved 8 Security level 0 = High, 1 = Maximum 7-6 Reserved 5 1 = Enhanced security erase supported 4 1 = Security count expired 3 1 = Security frozen 2 1 = Security locked 1 1 = Security enabled 0 1 = Security supported
129-144	32	*	Vendor unique
145-159	30	-	Vendor Unique (TDK using)
160	2	-	0000h: CFA power mode 1 (Not supported)
161	2	*	Reserved
162	2	-	0000h: Key Management schemes supported.(Not supported)
163-175	26	*	Reserved
176-255	140	-	0000h: Reserved / Not supported

(11) IDLE (97h or E3h)

This command is used to change the settings of the automatic power down sequence. Transition to the Partial Mode. When the Sector Count register is not 00h, the automatic power down sequence is executed, and immediately countdown is started. (Within the time equivalent to the numeric value of the Sector Count register multiplied by approx. 5ms, the device goes into the automatic power down sequence.) When the Sector Count register is 00h, the automatic power down sequence is prohibited. This setting is kept until the power on reset or the hard ware reset is execute, or reset setting by this command. This sequence can changed by using optional setting.(Please refer to "Optional setting" of Application Note) This command is no error termination.

Inputs

Register	7	6	5	4	3	2	1	0
Feature	na							
Sector Count	Timer period value							
Sector Number	na							
Cylinder Low	na							
Cylinder High	na							
Device/Head	na			0	na			
Command	97h or E3h							

Device/Head register: Drive No.(Fixed 0).

Sector Count register: Constant of the automatic power down timer

Normal outputs

Register	7	6	5	4	3	2	1	0
Error	na							
Sector Count	na							
Sector Number	na							
Cylinder Low	na							
Cylinder High	na							
Device/Head	na			0	na			
Status	BSY	DRAY	DWF	DSC	DRQ	CORR	na	ERR

Status register: 50h (10h when DRDY is cleared to 0)

(12) IDLE IMMEDIATE (95h or E1h)

Transition to the Partial Mode.

Inputs

Register	7	6	5	4	3	2	1	0
Feature	na							
Sector Count	na							
Sector Number	na							
Cylinder Low	na							
Cylinder High	na							
Device/Head	na			0	na			
Command	95h or E1h							

Device/Head register: Drive No.(Fixed 0).

Normal outputs

Register	7	6	5	4	3	2	1	0	
Error	na								
Sector Count	na								
Sector Number	na								
Cylinder Low	na								
Cylinder High	na								
Device/Head	na			0	na				
Status	BSY	DRAY	DWF	DSC	DRQ	CORR	na	ERR	

Status register: 50h (10h when DRDY is cleared to 0)

(13) INITIALIZE DEVICE PARAMETERS (91h)

By issuing this command, the host is able to specify the number of sectors(8 bits) per track and the value(4 bits) calculated by the number of heads per cylinder – 1. This command does not check the validity of the number of sectors and the number of heads. If they are invalid values, an IDNF error is reported when an invalid access from other commands occurs. When the number of cylinders calculated by provided parameters exceeds FFFFh, FFFFh is returned to the 54th word of the parameter which is returned to IDENTIFY DEVICE command, and this value is also used for the address conversion from CHS to LBA. This command is no error termination.

Inputs

Register	7	6	5	4	3	2	1	0	
Feature	na								
Sector Count	logical sector number per track								
Sector Number	na								
Cylinder Low	na								
Cylinder High	na								
Device/Head	na			0	Max Head				
Command	97h or E3h								

Sector Count register: The number of sectors per track

Device/Head register: Drive No.(Fixed 0), The number of heads – 1

Normal outputs

Register	7	6	5	4	3	2	1	0	
Error	na								
Sector Count	na								
Sector Number	na								
Cylinder Low	na								
Cylinder High	na								
Device/Head	na			0	na				
Status	BSY	DRAY	DWF	DSC	DRQ	CORR	na	ERR	

Status register: 50h (10h when DRDY is cleared to 0)

(14) NOP(00h)

This command is always terminated abnormally. It operates regardless of the state of the support of the NOP command (value of bit 14 of Word82 of IDENTIFY DEVICE command parameter information).

Inputs

Register	7	6	5	4	3	2	1	0
Feature	na							
Sector Count	na							
Sector Number	na							
Cylinder Low	na							
Cylinder High	na							
Device/Head	na			0	na			
Command	00h							

Device/Head register: Drive No.(Fixed 0).

Normal outputs

Register	7	6	5	4	3	2	1	0
Error	na					ABRT	na	
Sector Count	na							
Sector Number	na							
Cylinder Low	na							
Cylinder High	na							
Device/Head	na			0	na			
Status	BSY	DRAY	DWF	DSC	DRQ	CORR	na	ERR

Status register: 50h(10h when DRDY is cleared to 0)

Error register: 04h

Extended Error code: 20h

(15) READ BUFFER(E4h)

This command enables the host to read 1 sector data from the host buffer. It operates regardless of the state of the support of the READ BUFFER command (value of bit 13 of Word82 of IDENTIFY DEVICE command parameter information). This command is no error termination.

Inputs

Register	7	6	5	4	3	2	1	0
Feature	na							
Sector Count	na							
Sector Number	na							
Cylinder Low	na							
Cylinder High	na							
Device/Head	na			0	Max Head			
Command	E4h							

Device/Head register: Drive No.(Fixed 0).

Normal outputs

Register	7	6	5	4	3	2	1	0	
Error	na								
Sector Count	na								
Sector Number	na								
Cylinder Low	na								
Cylinder High	na								
Device/Head	na			0	na				
Status	BSY	DRAY	DWF	DSC	DRQ	CORR	na	ERR	

Status register: 50h (10h when DRDY is cleared to 0)

(16) READ DMA(C8h or C9h)

This command is used to read data equivalent to the number of sectors specified in the Sector Count register starting from the sector number specified in the task file register, and to send it to the host in the DMA mode. It can read from 1 to 256 sectors. When 00h is set to the Sector Count register, data transfer equivalent to 256 sectors is processed. DRQ is set in the same way as READ SECTOR(S) command, and an interruption occurs only when the command is completed. The DMA transfer is executed in the mode that has been selected (It is selected by bit 8-10 of IDENTIFY DEVICE command parameter information Word63 or bit 8-10 of Word88.). When the DMA transfer mode is not specified, the command is executed in Multiword DMA mode 0.

If an error occurs while the command is being executed, the ERR bit is set to the Status register after all the specified sectors are sent. Data after an error occurs are not valid. Even if the 8-bit transfer is enabled by SET FEATURES command, this command is operated in 16 bits.

The auto recovery function can be selected. Please refer to Data Sheet (General) of Option set up of Read command recovery.

Inputs

Register	7	6	5	4	3	2	1	0
Feature	na							
Sector Count	Sector Count							
Sector Number	Sector Number or LBA [7:0]							
Cylinder Low	Cylinder Low or LBA [15:8]							
Cylinder High	Cylinder High or LBA [23:16]							
Device/Head	na	LBA	na	0	Head or LBA [27:24]			
Command	C8h or C9h							

Sector Count register: The number of sectors to be read (256 sectors are transferred in the case of 00h)

Sector Number register: Starting sector address to be read (CHS: Sector address/LBA: LBA [7:0])

Cylinder Low register: Starting sector address to be read (CHS: Lower cylinder address/LBA: LBA [15:8])

Cylinder High register: Starting sector address to be read (CHS: Upper cylinder address/LBA: LBA [23:16])

Device/Head register: Starting sector address to be read (CHS: Head address/LBA: LBA [27:24]), Drive No.(Fixed 0), LBA flag

Normal outputs

Register	7	6	5	4	3	2	1	0
Error	na							
Sector Count	00h							
Sector Number	Sector Number or LBA [7:0]							
Cylinder Low	Cylinder Low or LBA [15:8]							
Cylinder High	Cylinder High or LBA [23:16]							
Device/Head	na	LBA	na	0	Head or LBA [27:24]			
Status	BSY	DRAY	DWF	DSC	DRQ	CORR	na	ERR

Status register: 50h

Sector Count register: 00h

Sector Number register: Last read sector address (CHS: Sector address/LBA: LBA [7:0])

Cylinder Low register: Last read sector address (CHS: Lower cylinder address/LBA: LBA [15:8])

Cylinder High register: Last read sector address (CHS: Upper cylinder address/LBA: LBA [23:16])

Device/Head register: Last read sector address (CHS: Head address/LBA: LBA [27:24]), Drive No.(Fixed 0), LBA flag

(17) READ LONG SECTOR (22h or 23h)

Following the transfer of the user data in the requested sector, 1 sector of ECC information with 4-byte configuration is read as FFFFFFFFh. Regardless of the setting of Long command of SET FEATURES command, the number of ECC information additional bytes is 4 bytes in this command.

Inputs

Register	7	6	5	4	3	2	1	0
Feature	na							
Sector Count	na							
Sector Number	Sector Number or LBA [7:0]							
Cylinder Low	Cylinder Low or LBA [15:8]							
Cylinder High	Cylinder High or LBA [23:16]							
Device/Head	na	LBA	na	0	Head or LBA [27:24]			
Command	22h or 23h							

Sector Count register: na

Sector Number register: Sector address to be read (CHS: Sector address/LBA: LBA [7:0])

Cylinder Low register: Sector address to be read (CHS: Lower cylinder address/LBA: LBA [15:8])

Cylinder High register: Sector address to be read (CHS: Upper cylinder address/LBA: LBA [23:16])

Device/Head register: Sector address to be read (CHS: Head address/LBA: LBA [27:24]), Drive No.(Fixed 0), LBA flag

Normal outputs

Register	7	6	5	4	3	2	1	0
Error	na							
Sector Count	00h							
Sector Number	Sector Number or LBA [7:0]							
Cylinder Low	Cylinder Low or LBA [15:8]							
Cylinder High	Cylinder High or LBA [23:16]							
Device/Head	na	LBA	na	0	Head or LBA [27:24]			
Status	BSY	DRAY	DWF	DSC	DRQ	CORR	na	ERR

Status register :50h

Sector Count register: 00h

Sector Number register: Read sector address (CHS: Sector address/LBA: LBA [7:0])

Cylinder Low register: Read sector address (CHS: Lower cylinder address/LBA: LBA [15:8])

Cylinder High register: Read sector address (CHS: Upper cylinder address/LBA: LBA [23:16])

Device/Head register: Read sector address (CHS: Head address/LBA: LBA [27:24]), Drive No.(Fixed 0), LBA flag

(18) READ MULTIPLE (C4h)

This command is the same as READ SECTOR(S) command except that an interruption occurs not for each sector transfer but for each block transfer that consists of the number of sectors defined by SET MULTIPLE command. When the nIEN bit(bit 0 of the Device Control register) is set (1), an interruption does not occur. The number of block counts (the number of sectors that make up a block) is possible to set 1, It operates regardless of the state of the support of the READ MULTIPLE command(value of lower byte of Word59 of IDENTIFY DEVICE command parameter information)..

The auto recovery function can be selected. Please refer to Data Sheet(General) of Option set up of Read command recovery.

Inputs

Register	7	6	5	4	3	2	1	0
Feature	na							
Sector Count	Sector Count							
Sector Number	Sector Number or LBA [7:0]							
Cylinder Low	Cylinder Low or LBA [15:8]							
Cylinder High	Cylinder High or LBA [23:16]							
Device/Head	na	LBA	na	0	Head or LBA [27:24]			
Command	22h or 23h							

Sector Count register: The number of sectors to be read (256 sectors are transferred in the case of 00h)

Sector Number register: Starting sector address to be read (CHS: Sector address/LBA: LBA [7:0])

Cylinder Low register: Starting sector address to be read (CHS: Lower cylinder address/LBA: LBA [15:8])

Cylinder High register: Starting sector address to be read (CHS: Upper cylinder address/LBA: LBA [23:16])

Device/Head register: Starting sector address to be read (CHS: Head address/LBA: LBA [27:24]), Drive No.(Fixed 0),LBA flag

Normal outputs

Register	7	6	5	4	3	2	1	0
Error	na							
Sector Count	00h							
Sector Number	Sector Number or LBA [7:0]							
Cylinder Low	Cylinder Low or LBA [15:8]							
Cylinder High	Cylinder High or LBA [23:16]							
Device/Head	na	LBA	na	0	Head or LBA [27:24]			
Status	BSY	DRAY	DWF	DSC	DRQ	CORR	na	ERR

Status register: 50h

Sector Count register: 00h

Sector Number register: Last read sector address (CHS: Sector address/LBA: LBA [7:0])

Cylinder Low register: Last read sector address (CHS: Lower cylinder address/LBA: LBA [15:8])

Cylinder High register: Last read sector address (CHS: Upper cylinder address/LBA: LBA [23:16])

Device/Head register: Last read sector address (CHS: Head address/LBA: LBA [27:24]), Drive No.(Fixed 0), LBA flag

(19) READ SECTOR(S)(20h or 21h)

This command is used to read data equivalent to the number of sectors specified in the Sector Count register starting from the sector number specified in the task file register. It can read from 1 to 256 sectors. When 00h is set to the Sector Count register, data transfer equivalent to 256 sectors is processed. Regardless of presence or absence of an error state, DRQ is always set (1) before data transfer.

If an uncorrectable error occurs, the reading operation is terminated at the sector where the error occurs, read data is stored in the host buffer, and the DRQ bit is set (1). When the last sector is exceeded during the reading operation, this command is terminated with an address overflow error after the data in the last sector is transferred to the host.

The auto recovery function can be selected. Please refer to Data Sheet(General) of Option set up of Read command recovery.

Inputs

Register	7	6	5	4	3	2	1	0
Feature	na							
Sector Count	Sector Count							
Sector Number	Sector Number or LBA [7:0]							
Cylinder Low	Cylinder Low or LBA [15:8]							
Cylinder High	Cylinder High or LBA [23:16]							
Device/Head	na	LBA	na	0	Head or LBA [27:24]			
Command	20h or 21h							

Sector Count register: The number of sectors to be read (256 sectors are transferred in the case of 00h)

Sector Number register: Starting sector address to be read (CHS: Sector address/LBA: LBA [7:0])

Cylinder Low register: Starting sector address to be read (CHS: Lower cylinder address/LBA: LBA [15:8])

Cylinder High register: Starting sector address to be read (CHS: Upper cylinder address/LBA: LBA [23:16])

Device/Head register: Starting sector address to be read (CHS: Head address/LBA: LBA [27:24]), Drive No.(Fixed 0), LBA flag

Normal outputs

Register	7	6	5	4	3	2	1	0
Error	na							
Sector Count	00h							
Sector Number	Sector Number or LBA [7:0]							
Cylinder Low	Cylinder Low or LBA [15:8]							
Cylinder High	Cylinder High or LBA [23:16]							
Device/Head	na	LBA	na	0	Head or LBA [27:24]			
Status	BSY	DRAY	DWF	DSC	DRQ	CORR	na	ERR

Status register: 50h

Sector Count register: 00h

Sector Number register: Last read sector address (CHS: Sector address/LBA: LBA [7:0])

Cylinder Low register: Last read sector address (CHS: Lower cylinder address/LBA: LBA [15:8])

Cylinder High register: Last read sector address (CHS: Upper cylinder address/LBA: LBA [23:16])

Device/Head register: Last read sector address (CHS: Head address/LBA: LBA [27:24]), Drive No.(Fixed 0), LBA flag

(20) READ VERIFY SECTOR(S)(40h or 41h)

This command is used to conduct ECC verification against the data equivalent to the number of sectors specified by the Sector Count register starting from the sector number specified by the task file register. In case of optional setting of READ VERIFY SECTOR(S) command correctable error set is enable and correctable error is detected, CORR bit of status register is set. Please refer to option setting of Data sheet

The auto recovery function can be selected. Please refer to Data Sheet (General) of Option set up of Read command recovery.

Inputs

Register	7	6	5	4	3	2	1	0
Feature	na							
Sector Count	Sector Count							
Sector Number	Sector Number or LBA [7:0]							
Cylinder Low	Cylinder Low or LBA [15:8]							
Cylinder High	Cylinder High or LBA [23:16]							
Device/Head	na	LBA	na	0	Head or LBA [27:24]			
Command	40h or 41h							

Sector Count register: The number of sectors to be read (256 sectors are transferred in the case of 00h)

Sector Number register: Starting sector address to be read (CHS: Sector address/LBA: LBA [7:0])

Cylinder Low register: Starting sector address to be read (CHS: Lower cylinder address/LBA: LBA [15:8])

Cylinder High register: Starting sector address to be read (CHS: Upper cylinder address/LBA: LBA [23:16])

Device/Head register: Starting sector address to be read (CHS: Head address/LBA: LBA [27:24]), Drive No.(Fixed 0),LBA flag

Normal outputs

Register	7	6	5	4	3	2	1	0
Error	na							
Sector Count	00h							
Sector Number	Sector Number or LBA [7:0]							
Cylinder Low	Cylinder Low or LBA [15:8]							
Cylinder High	Cylinder High or LBA [23:16]							
Device/Head	na	LBA	na	0	Head or LBA [27:24]			
Status	BSY	DRAY	DWF	DSC	DRQ	CORR	na	ERR

Status register: 50h

Sector Count register: 00h

Sector Number register: Last read sector address (CHS: Sector address/LBA: LBA [7:0])

Cylinder Low register: Last read sector address (CHS: Lower cylinder address/LBA: LBA [15:8])

Cylinder High register: Last read sector address (CHS: Upper cylinder address/LBA: LBA [23:16])

Device/Head register: Last read sector address (CHS: Head address/LBA: LBA [27:24]), Drive No.(Fixed 0), LBA flag

(21) RECALIBRATE (1Xh)

This command is treated as NOP in this device.

Inputs

Register	7	6	5	4	3	2	1	0
Feature	na							
Sector Count	na							
Sector Number	na							
Cylinder Low	na							
Cylinder High	na							
Device/Head	na	LBA	na	0	na			
Command	1Xh							

Device/Head register: Drive No.(Fixed 0), LBA flag

Normal outputs

Register	7	6	5	4	3	2	1	0
Error	na							
Sector Count	na							
Sector Number	na							
Cylinder Low	na							
Cylinder High	na							
Device/Head	na			0	na			
Status	BSY	DRAY	DWF	DSC	DRQ	CORR	na	ERR

Status register: 50h(10h when DRDY is cleared to 0)

(22) SECURITY DISABLE PASSWORD (F6h)

This command disables the user password for the Security command. It sends one sector data as shown below to this device.

Comparing the password sent from the host and the user password or master password stored in this device and finding that they match, this command disables the user password stored in this device. If the Security command is not supported, the command is aborted.

Data Structure

Byte	Description
0	bit0:0=User password comparison 1=Master password comparison bit1-7:Reserved
1	Reserved
2-33	Password(32-byte)
34-511	Reserved

Inputs

Register	7	6	5	4	3	2	1	0
Feature	na							
Sector Count	na							
Sector Number	na							
Cylinder Low	na							
Cylinder High	na							
Device/Head	na			0	na			
Command	F6h							

Device/Head register: Device Number

Normal outputs

Register	7	6	5	4	3	2	1	0
Error	na							
Sector Count	na							
Sector Number	na							
Cylinder Low	na							
Cylinder High	na							
Device/Head	na			0	na			
Status	BSY	DRAY	DWF	DSC	DRQ	CORR	na	ERR

Status register: 50h

Device/Head register: Device Number

(23) SECURITY ERASE PREPARE(F3h)

This command enables the SECURITY ERASE UNIT command that will be issued immediately after this command is executed. If the Security command is not supported, the command is aborted.

Inputs

Register	7	6	5	4	3	2	1	0
Feature	na							
Sector Count	na							
Sector Number	na							
Cylinder Low	na							
Cylinder High	na							
Device/Head	na			0	na			
Command	F3h							

Device/Head register: Device Number

Normal outputs

Register	7	6	5	4	3	2	1	0
Error	na							
Sector Count	na							
Sector Number	na							
Cylinder Low	na							
Cylinder High	na							
Device/Head	na			0	na			
Status	BSY	DRAY	DWF	DSC	DRQ	CORR	na	ERR

Status register: 50h

Device/Head register: Device Number

(24) SECURITY ERASE UNIT(F4h)

This command erase all user areas and disables the user password for the Security command. It sends one sector data as shown below to this device. Comparing the password sent from the host and the user password or master password stored in this device and finding that they match, this command executes the processing. Normal Erase and Enhanced Erase are existing erasing methods, but this device is only support Normal Erase, not support Enhanced Erase. If Enhanced Erase is specified, the command is aborted. If the SECURITY ERASE PREPARE command is not executed just before this command, the command is aborted. If the Security command is not supported or Security is disabled, the command is aborted.

Data Structure

Byte	Description
0	bit0:0=User password comparison 1=Master password comparison bit1:0=Normal Erase 1=Enhanced Erase bit2-7:Reserved
1	Reserved
2-33	Password(32-byte)
34-511	Reserved(FFh)

Inputs

Register	7	6	5	4	3	2	1	0
Feature	na							
Sector Count	na							
Sector Number	na							
Cylinder Low	na							
Cylinder High	na							
Device/Head	na			0	na			
Command	F4h							

Device/Head register: Device Number

Normal outputs

Register	7	6	5	4	3	2	1	0
Error	na							
Sector Count	na							
Sector Number	na							
Cylinder Low	na							
Cylinder High	na							
Device/Head	na			0	na			
Status	BSY	DRAY	DWF	DSC	DRQ	CORR	na	ERR

Status register: 50h

Device/Head register: Device Number

(25) SECURITY FREEZE LOCK(F5h)

After this command is executed, Security related commands other than this command are aborted. When the Security command is not supported in the Identify Device parameters, this command is worked as "NOP".

Inputs

Register	7	6	5	4	3	2	1	0
Feature	na							
Sector Count	na							
Sector Number	na							
Cylinder Low	na							
Cylinder High	na							
Device/Head	na			0	na			
Command	F5h							

Device/Head register: Device Number

Normal outputs

Register	7	6	5	4	3	2	1	0
Error	na							
Sector Count	na							
Sector Number	na							
Cylinder Low	na							
Cylinder High	na							
Device/Head	na			0	na			
Status	BSY	DRAY	DWF	DSC	DRQ	CORR	na	ERR

Status register: 50h

Device/Head register: Device Number

(26) SECURITY SET PASSWORD (F1h)

This command sets passwords for the Security command. It sends one sector data as shown below to this device. If selected the master password, the master password and the master password revision code is stored. If selected the user password, the user password and security level is stored. Security is enabled when user password is selected. Range of master password revision code is 0001h to FFEh. Security enable / disable, security level and master password revision code can read IDENTIFY DEVICE command. If the Security command is not supported, the command is aborted.

Data Structure

Byte	Description
0	bit0:0=User password setting 1=Master password setting bit1-7:Reserved
1	bit0:0=Security level High 1=Security level Maximum bit1-7:Reserved
2-33	Password(32-byte)
34-35	Master password revision code(only for the master password)
36-511	Reserved(FFh)

Inputs

Register	7	6	5	4	3	2	1	0
Feature	na							
Sector Count	na							
Sector Number	na							
Cylinder Low	na							
Cylinder High	na							
Device/Head	na			0	na			
Command	F1h							

Device/Head register: Device Number

Normal outputs

Register	7	6	5	4	3	2	1	0
Error	na							
Sector Count	na							
Sector Number	na							
Cylinder Low	na							
Cylinder High	na							
Device/Head	na			0	na			
Status	BSY	DRAY	DWF	DSC	DRQ	CORR	na	ERR

Status register: 50h

Device/Head register: Device Number

(27) SECURITY UNLOCK (F2h)

This command unlocks the locked Security status It sends one sector data as shown below to this device. Comparing the password sent from the host and the user password or master password stored in this device and finding that they match, this command executes the processing. If the Security command is not supported, the command is aborted.

Data Structure

Byte	Description
0	bit0 0=User password comparison 1=Master password comparison bit 1-7:Reserved
1	Reserved
2-33	Password(32-byte)
34-511	Reserved(FFh)

Inputs

Register	7	6	5	4	3	2	1	0
Feature	na							
Sector Count	na							
Sector Number	na							
Cylinder Low	na							
Cylinder High	na							
Device/Head	na			0	na			
Command	F2h							

Device/Head register: Device Number

Normal outputs

Register	7	6	5	4	3	2	1	0
Error	na							
Sector Count	na							
Sector Number	na							
Cylinder Low	na							
Cylinder High	na							
Device/Head	na			0	na			
Status	BSY	DRAY	DWF	DSC	DRQ	CORR	na	ERR

Status register: 50h

Device/Head register: Device Number

(28) SEEK(7Xh)

Although this command is usually used to seek the track specified by the task file register, it is treated as NOP in this device.

Inputs

Register	7	6	5	4	3	2	1	0
Feature	na							
Sector Count	na							
Sector Number	Sector Number or LBA [7:0]							
Cylinder Low	Cylinder Low or LBA [15:8]							
Cylinder High	Cylinder High or LBA [23:16]							
Device/Head	na	LBA	na	0	Head or LBA [27:24]			
Command	7Xh							

Sector Number register: Sector address to be sought (CHS: Sector address/LBA: LBA [7:0])

Cylinder Low register: Sector address to be sought (CHS: Lower cylinder address/LBA: LBA [15:8])

Cylinder High register: Sector address to be sought (CHS: Upper cylinder address/LBA: LBA [23:16])

Device/Head register: Sector address to be sought (CHS: Head address/LBA: LBA [27:24]), Drive No.(Fixed 0)., LBA flag

Normal outputs

Register	7	6	5	4	3	2	1	0
Error	na							
Sector Count	00h							
Sector Number	Sector Number or LBA [7:0]							
Cylinder Low	Cylinder Low or LBA [15:8]							
Cylinder High	Cylinder High or LBA [23:16]							
Device/Head	na	LBA	na	0	Head or LBA [27:24]			
Status	BSY	DRAY	DWF	DSC	DRQ	CORR	na	ERR

Status register: 50h (10h when DRDY is cleared to 0)

Sector Number register: Sought sector address (CHS: Sector address/LBA: LBA [7:0])

Cylinder Low register: Sought sector address (CHS: Lower cylinder address/LBA: LBA [15:8])

Cylinder High register: Sought sector address (CHS: Upper cylinder address/LBA: LBA [23:16])

Device/Head register: Sought sector address (CHS: Head address/LBA: LBA [27:24]), Drive No.(Fixed 0)., LBA flag

(29) SET FEATURES (EFh)

This command is used to change some of the operational settings of this device. When Subcommand Code other than Support or NOP in the following table are specified, the command is aborted because of non-support parameter error..

Table 6: Feature Supported

Feature	Support	Operation
01h	Support	Enable 8bit Data Transfer
02h	NOP	Enable write cache
03h	****	Set transfer mode based on value in Sector Count register. See the table below(Transfer Mode)
10h	Support	Enable use of Serial ATA feature
55h	NOP	Disable Read Lock Ahead
66h	Support	Disable Power on Reset establishment of defaults at Soft Reset
69h	NOP	NOP – Accepted for backward compatibility
81h	Support	Disable 8bit Data Transfer
82h	NOP	Disable write cache
90h	Support	Disable use of Serial ATA feature
96h	NOP	NOP - Accepted for backward compatibility.
97h	NOP	Accepted for backward compatibility
9Ah	NOP	NOP – Set the host current source capability
BBh	NOP	4 bytes of data apply on Read/Write Long commands.
CCh	Support	Enable Power on Reset (POR) establishment of defaults at Soft Reset.

Table 7: Transfer mode values

Subcommand specific	Mode
00h、01h	PIO default setting
08h	PIO mode 0 setting
09h	PIO mode 1 setting
0Ah	PIO mode 2 setting
0Bh	PIO mode 3 setting
0Ch	PIO mode 4 setting
20h	Multiword DMA mode 0 setting
21h	Multiword DMA mode 1 setting
22h	Multiword DMA mode 2 setting
40h	Ultra DMA mode 0 setting
41h	Ultra DMA mode 1 setting
42h	Ultra DMA mode 2 setting
Others	Not supported parameter error

Note) If you specify a mode that is not supported, it results in a non-supported parameter error. For information on the transfer mode setting, see IDENTIFY DEVICE commands related specifications.

Enable/Disable 8bit Data Transfer(01h/81h)

The 8-bit transfer is disabled when the power is turned on or after the hardware is reset.

Enable/Disable Power on Reset establishment of default at Soft reset(66h/CCh)

When this setting is enabled ,there is an item not returned to the default value in case of ATA software reset is processed

It is effective/invalid of the forwarding mode and forwarding eight bits of Ultra DMA. Multiple is always enable (Multiple=1)

The default of this setting is enable

Enable/Disable use of Serial ATA feature(10h/90h)

The Sector Count register contains the specific Serial ATA feature to enable or disable.

Subcommand specific	Mode
03h	Device-initiated interface power state transitions

Inputs

Register	7	6	5	4	3	2	1	0
Feature	Subcommand code							
Sector Count	Subcommand specific							
Sector Number	na							
Cylinder Low	na							
Cylinder High	na							
Device/Head	na			0	na			
Command	EFh							

Device/Head register: Drive No. (Fixed 0).

Features register: Function change parameter (See the codes in the table above)

Sector Count register: PIO mode value (When the Features register = 03h)

Normal outputs

Register	7	6	5	4	3	2	1	0
Error	na							
Sector Count	na							
Sector Number	na							
Cylinder Low	na							
Cylinder High	na							
Device/Head	na			0	na			
Status	BSY	DRAY	DWF	DSC	DRQ	CORR	na	ERR

Sector register: 50h (10h when DRDY is cleared to 0)

(30) SET MULTIPLE MODE(C6h)

This command is used to permit or prohibit Multiple commands(READ MULTIPLE, WRITE MULTIPLE, and CFA WRITE MULTIPLE WITHOUT ERASE commands) by setting the number of block counts (i.e., the number of sectors that compose a block) for Multiple commands. When the Sector Count register is set to 01h, Multiple commands to be issued subsequently are permitted. When the Sector Count register is set to 00h, they are prohibited. If the register is set to other values, the Status register is set (1) to D0(ABRT), and Multiple commands to be issued after that are prohibited. In this device, specification of only 1 sector for one block is supported. Multiple commands are prohibited when the power is turned on or the hardware is reset.

When this command is executed, the setting values are reflected in the lower byte of the word 59 in the IDENTIFY DEVICE information. (If Multiple commands are prohibited, 00h is set.)

This device always can operates Multiple commands regardless of the this command or IDENTIFY DEVICE command parameter information.

Inputs

Register	7	6	5	4	3	2	1	0
Feature	na							
Sector Count	Sector Number per block							
Sector Number	na							
Cylinder Low	na							
Cylinder High	na							
Device/Head	na			0	na			
Command	EFh							

Device/Head register: Drive No. (Fixed 0).

Sector Count register: Number of sectors per block

Normal outputs

Register	7	6	5	4	3	2	1	0
Error	na							
Sector Count	na							
Sector Number	na							
Cylinder Low	na							
Cylinder High	na							
Device/Head	na			0	na			
Status	BSY	DRAY	DWF	DSC	DRQ	CORR	na	ERR

Sector register: 50h (10h when DRDY is cleared to 0)

SATA DiskOnModule

(31) SLEEP (99h or E6h)

This mode is used to make the device go into the sleep mode regardless of the present power down mode. Transition to the Slumber Mode.

With this command, the device clears the BSY(to 0), causes an interruption if the nLEN bit(bit 0 of the Device Control register) is cleared (0), and then goes into the sleep mode. It returns from the sleep mode next time a command or reset is issued from the host.

This command is no error termination.

Inputs

Register	7	6	5	4	3	2	1	0
Feature	na							
Sector Count	na							
Sector Number	na							
Cylinder Low	na							
Cylinder High	na							
Device/Head	na			0	na			
Command	99h or E6h							

Device/Head register: Drive No. (Fixed 0).

Normal outputs

Register	7	6	5	4	3	2	1	0
Error	na							
Sector Count	na							
Sector Number	na							
Cylinder Low	na							
Cylinder High	na							
Device/Head	na			0	na			
Status	BSY	DRAY	DWF	DSC	DRQ	CORR	na	ERR

Status register: 50h (10h when DRDY is cleared to 0)

(32) SMART DISABLE OPERATIONS (B0h [sub code D9h])

When this command is received, all the functions of SMART commands are disabled, and SMART commands except SMART ENABLE OPERATIONS are not accepted. When SMART commands are disabled, Word85 bit 0 of the IDENTIFY DEVICE information is set to 0.

When the SMART command is invalid(Bit 0 of IDENTIFY DEVICE command parameter information Word 85 is 0), This command is terminated non-support command error.

Inputs

Register	7	6	5	4	3	2	1	0
Feature	D9h							
Sector Count	na							
Sector Number	na							
Cylinder Low	4Fh							
Cylinder High	C2h							
Device/Head	na			0	na			
Command	B0h							

Features register: D9 (sub code)

Cylinder Low: 4Fh (Fixed)

Cylinder High: C2h (fixed)

Device/Head register: Drive No. (Fixed 0).

Normal outputs

Register	7	6	5	4	3	2	1	0	
Error	na								
Sector Count	na								
Sector Number	na								
Cylinder Low	na								
Cylinder High	na								
Device/Head	na			0	na				
Status	BSY	DRAY	DWF	DSC	DRQ	CORR	na	ERR	

Status register: 50h (10h when DRDY is cleared to 0)

(33) SMART ENABLE/DISABLE ATTRIBUTE AUTOSAVE (B0h [sub code D2h])

Although, this command is used to switch enable/disable of attribute autoseve function, it is considered as a NOP process in this device.

Inputs

Register	7	6	5	4	3	2	1	0	
Feature	D2h								
Sector Count	na								
Sector Number	na								
Cylinder Low	4Fh								
Cylinder High	C2h								
Device/Head	na			0	na				
Command	B0h								

Features register: D2h (sub code)

Cylinder Low: 4Fh (Fixed)

Cylinder High: C2h (Fixed)

Device/Head register: Drive No. (Fixed 0)

Normal outputs

Register	7	6	5	4	3	2	1	0	
Error	na								
Sector Count	na								
Sector Number	na								
Cylinder Low	na								
Cylinder High	na								
Device/Head	na			0	na				
Status	BSY	DRAY	DWF	DSC	DRQ	CORR	na	ERR	

Status register: 50h (10h when DRDY is cleared to 0)

SATA DiskOnModule

(34) SMART ENABLE OPERATIONS (B0h [sub code D8h])

When this command is received, all the functions of SMART commands are enabled, and SMART commands become accepted. If SMART commands are already enabled, this command is completed normally, leaving SMART commands enabled. When SMART commands are enabled, Word85 bit 0 of the IDENTIFY DEVICE information is set to 1.

Inputs

Register	7	6	5	4	3	2	1	0
Feature	D8h							
Sector Count	na							
Sector Number	na							
Cylinder Low	4Fh							
Cylinder High	C2h							
Device/Head	na			0	na			
Command	B0h							

Features register: D8h (sub code)

Cylinder Low: 4Fh (Fixed)

Cylinder High: C2h (Fixed)

Device/Head register: Drive No. (Fixed 0)

Normal outputs

Register	7	6	5	4	3	2	1	0
Error	na							
Sector Count	na							
Sector Number	na							
Cylinder Low	na							
Cylinder High	na							
Device/Head	na			0	na			
Status	BSY	DRAY	DWF	DSC	DRQ	CORR	na	ERR

Status register: 50h

(35) SMART READ DATA (B0h [sub code D0h])

This command returns the total number of blocks, the number of blocks in use, the number of deleted blocks, the number of originally defective blocks, the number of acquired defective blocks, and the number of other defective blocks of each chip of the connected flash memory as 1-sector data. Even if SMART commands are not supported (Bit 0 of IDENTIFY DEVICE command parameter information Word 82 is 0), or when they are disabled (Bit 0 of IDENTIFY DEVICE command parameter information Word 85 is 0), this command can execute.

Inputs

Register	7	6	5	4	3	2	1	0
Feature	D0h							
Sector Count	na							
Sector Number	na							
Cylinder Low	4Fh							
Cylinder High	C2h							
Device/Head	na			0	na			
Command	B0h							

Features register: D0h (sub code)

Cylinder Low: 4Fh (Fixed)

Cylinder High: C2h (Fixed)

Device/Head register: Drive No. (Fixed 0)

Normal outputs

Register	7	6	5	4	3	2	1	0
Error	na							
Sector Count	na							
Sector Number	na							
Cylinder Low	na							
Cylinder High	na							
Device/Head	na			0	na			
Status	BSY	DRAY	DWF	DSC	DRQ	CORR	na	ERR

Status register: 50h

Data Structure

Byte	Item	Value
0-361	Vendor specific	00h
362	Off-line collection data status	00h(Not supported)
363	Self-test execution status byte	00h(Not supported)
364-365	Total Time Secounds to complete off-line data collection activity	0000h(Not supported)
366	Vendor specific	00h
367	Off-line data collection capability	00h(Not supported)
368-369	SMART capability	00h
370	Error logging capability	00h(Not supported)
371	Error logging capability	00h
372	Short self-test routine recommended polling time(in minutes)	00h(Not supported)
373	Extended self-test routine recommended polling time(in minutes)	00h(Not supported)
374	Conveyance self-test routine recommended polling time(in minutes)	00h(Not supported)
375-385	Reserved	00h
386-510	Block Condition(Vendor specific)	XXh
511	Checksum	XXh

(a) Block Condition

Byte	Item
386	Number of connected chips
387	Value of byte 1 of the device ID of chip 0
388	Value of byte 2 of the device ID of chip 0
389	Value of byte 3 of the device ID of chip 0
390	Value of byte 4 of the device ID of chip 0
391	Value of byte 5 of the device ID of chip 0
392-395	Total number of blocks(4 bytes)
396-397	Threshold value of the number of deleted blocks
398-401	Reserved(na)
402-413	Chip 0 block information
414-425	Chip 1 block information
426-437	Chip 2 block information
438-449	Chip 3 block information
450-461	Chip 4 block information
462-473	Chip 5 block information
474-485	Chip 6 block information
486-497	Chip 7 block information
498-499	Minimum values of number of deleted blocks par zone
500	Chip number has zone which minimum values of number of deleted blocks par zone
501-510	Reserved(na)

Block Information of each chip

Byte	Item
0-1	Total number of blocks(2 bytes)
2-3	Number of blocks in use(2 bytes)
4-5	Number of deleted blocks(2 bytes)
6-7	Number of original defective blocks(2 bytes)
8-9	Number of acquired defective blocks(2 bytes)
10-11	Number of other defective blocks(2 bytes)

Other defective blocks refers to those that cannot be identified as either original or acquired defective blocks. The User Info block and a block in which a read timeout error occurs are counted as a block in use. Block information of the chip not connected is all 00h.

(b)Checksum

The data structure checksum is the two's complement of the sum of the first 511 bytes in the data structure. Each byte shall be added with unsigned arithmetic, and overflow shall be ignored.

(36) SMART RETURN STATUS (B0h [sub code DAh])

This command returns “when the system is abnormal” when there is a zone in which the number of deleted blocks(per zone) is smaller than a specified threshold value.

Inputs

Register	7	6	5	4	3	2	1	0
Feature	DAh							
Sector Count	na							
Sector Number	na							
Cylinder Low	4Fh							
Cylinder High	C2h							
Device/Head	na			0	na			
Command	B0h							

Features register: DAh (sub code)

Cylinder Low: 4Fh (Fixed)

Cylinder High: C2h (Fixed)

Device/Head register: Drive No. (Fixed 0)

Normal outputs

Register	7	6	5	4	3	2	1	0
Error	na							
Sector Count	na							
Sector Number	na							
Cylinder Low	4Fh or F4h							
Cylinder High	C2h or 2Ch							
Device/Head	na			0	na			
Status	BSY	DRAY	DWF	DSC	DRQ	CORR	na	ERR

Status register: 50h (10h when DRDY is cleared to 0)

Cylinder Low: 4Fh (when the system is normal) F4h (when system is abnormal)

Cylinder High: C2h (when the system is normal) 2Ch (when system is abnormal)

(37) STANDBY (96h or E2h)

When this device receives this command, it goes into the sleep mode after approx. 5ms regardless of the value of the Sector Count register. Transition to the Slumber Mode. This does not affect the power down mode value and timer count value. This command is no error termination.

Inputs

Register	7	6	5	4	3	2	1	0
Feature	na							
Sector Count	na							
Sector Number	na							
Cylinder Low	na							
Cylinder High	na							
Device/Head	na			0	na			
Command	96h or E2h							

Device/Head register: Drive No. (Fixed 0).

Normal outputs

Register	7	6	5	4	3	2	1	0	
Error	na								
Sector Count	na								
Sector Number	na								
Cylinder Low	na								
Cylinder High	na								
Device/Head	na			0	na				
Status	BSY	DRAY	DWF	DSC	DRQ	CORR	na	ERR	

Status register: 50h (10h when DRDY is cleared to 0)

(38) STANDBY IMMEDIATE (94h or E0h)

When this device receives this command, it goes into the sleep mode after approx. 5ms. This command performs the same operation as STANDBY command. Transition to the Slumber Mode. This command is no error termination.

Inputs

Register	7	6	5	4	3	2	1	0	
Feature	na								
Sector Count	na								
Sector Number	na								
Cylinder Low	na								
Cylinder High	na								
Device/Head	na			0	na				
Command	94h or E0h								

Device/Head register: Drive No. (Fixed 0).

Normal outputs

Register	7	6	5	4	3	2	1	0	
Error	na								
Sector Count	na								
Sector Number	na								
Cylinder Low	na								
Cylinder High	na								
Device/Head	na			0	na				
Status	BSY	DRAY	DWF	DSC	DRQ	CORR	na	ERR	

Status register: 50h (10h when DRDY is cleared to 0)

(39) WRITE BUFFER (E8h)

This command is used to rewrite the data in the host buffer into the pattern that can be transferred from the host. This command is no error termination. Even if WRITE BUFFER commands are not supported(Bit 12 of IDENTIFY DEVICE command parameter information Word 82 is 0), this command can execute.

Inputs

Register	7	6	5	4	3	2	1	0
Feature	na							
Sector Count	na							
Sector Number	na							
Cylinder Low	na							
Cylinder High	na							
Device/Head	na			0	na			
Command	E8h							

Device/Head register: Drive No. (Fixed 0).

Normal outputs

Register	7	6	5	4	3	2	1	0
Error	na							
Sector Count	na							
Sector Number	na							
Cylinder Low	na							
Cylinder High	na							
Device/Head	na			0	na			
Status	BSY	DRAY	DWF	DSC	DRQ	CORR	na	ERR

Status register: 50h (10h when DRDY is cleared to 0)

(40) WRITE DMA (CAh or CBh)

This command is used to write the data which was transferred from the host in the DMA mode equivalent to the number of sectors specified in the Sector Count register starting from the sector number specified in the task file register. When the Sector Count register is set to 0, it is processed as data transfer equivalent to 256 sectors. DRQ is set in the same way as WRITE SECTOR(S) command, and an interruption occurs only when the command is completed. DMA transfer mode is can be select by set feature command. It can be check (bit 8-10 of IDNENTIFY DEVICE command parameter information Word 80 or bit 8-10 of IDNENTIFY DEVICE command parameter information Word 82 is 0. If DMA MODE is not selected, Multiword DMA mode 0 is selected If an error occurs while the command is being executed, the ERR bit is set to the Status register after all the specified sectors are sent. Data after an error occurs are not written. Even if the 8-bit transfer is enabled by SET FEATURES command, this command is operated in 16 bits.

Inputs

Register	7	6	5	4	3	2	1	0
Feature	na							
Sector Count	Sector Count							
Sector Number	Sector Number or LBA [7:0]							
Cylinder Low	Cylinder Low or LBA [15:8]							
Cylinder High	Cylinder High or LBA [23:16]							
Device/Head	na	LBA	na	0	Head or LBA [27:24]			
Command	CAh or CBh							

Sector Count register: The number of sectors to be written (256 sectors are transferred in the case of 00h)

Sector Number register: Starting sector address to be written (CHS: Sector address/LBA: LBA [7:0])

Cylinder Low register: Starting sector address to be written (CHS: Lower cylinder address/LBA: LBA [15:8])

Cylinder High register: Starting sector address to be written (CHS: Upper cylinder address/LBA: LBA [23:16])

Device/Head register: Starting sector address to be written (CHS: Head address/LBA: LBA [27:24]), Drive No.(Fixed 0), LBA flag

Normal outputs

Register	7	6	5	4	3	2	1	0
Error	na							
Sector Count	00h							
Sector Number	Sector Number or LBA [7:0]							
Cylinder Low	Cylinder Low or LBA [15:8]							
Cylinder High	Cylinder High or LBA [23:16]							
Device/Head	na	LBA	na	0	Head or LBA [27:24]			
Status	BSY	DRAY	DWF	DSC	DRQ	CORR	na	ERR

Status register: 50h

Sector Count register: 00h

Sector Number register: Last written sector address (CHS: Sector address/LBA: LBA [7:0])

Cylinder Low register: Last written sector address (CHS: Lower cylinder address/LBA: LBA [15:8])

Cylinder High register: Last written sector address (CHS: Upper cylinder address/LBA: LBA [23:16])

Device/Head register: Last written sector address (CHS: Head address/LBA: LBA [27:24]), Drive No.(Fixed 0), LBA flag

(41) WRITE LONG SECTOR (32h or 33h)

This command is used to receive 4-byte ECC information from the host after 512-byte sector data and write the sector data only.

This command transfers only 1 sector(512 bytes + 4 bytes). Regardless of the settings related to Long command of SET

FEATURES command, ECC information handled by this command is 4 bytes.

Inputs

Register	7	6	5	4	3	2	1	0
Feature	na							
Sector Count	na							
Sector Number	Sector Number or LBA [7:0]							
Cylinder Low	Cylinder Low or LBA [15:8]							
Cylinder High	Cylinder High or LBA [23:16]							
Device/Head	na	LBA	na	0	Head or LBA [27:24]			
Command	32h or 33h							

Sector Count register: na

Sector Number register: Sector address to be written (CHS: Sector address/LBA: LBA [7:0])

Cylinder Low register: Sector address to be written (CHS: Lower cylinder address/LBA: LBA [15:8])

Cylinder High register: Sector address to be written (CHS: Upper cylinder address/LBA: LBA [23:16])

Device/Head register: Sector address to be written (CHS: Head address/LBA: LBA [27:24]), Drive No.(Fixed 0), LBA flag

Normal outputs

Register	7	6	5	4	3	2	1	0
Error	na							
Sector Count	00h							
Sector Number	Sector Number or LBA [7:0]							
Cylinder Low	Cylinder Low or LBA [15:8]							
Cylinder High	Cylinder High or LBA [23:16]							
Device/Head	na	LBA	na	0	Head or LBA [27:24]			
Status	BSY	DRAY	DWF	DSC	DRQ	CORR	na	ERR

Status register: 50h

Sector Count register: 00h

Sector Number register: Written sector address (CHS: Sector address/LBA: LBA [7:0])

Cylinder Low register: Written sector address (CHS: Lower cylinder address/LBA: LBA [15:8])

Cylinder High register: Written sector address (CHS: Upper cylinder address/LBA: LBA [23:16])

Device/Head register: Written sector address (CHS: Head address/LBA: LBA [27:24]), Drive No.(Fixed 0), LBA flag

(42) WRITE MULTIPLE (C5h)

This command is the same as WRITE SECTOR(S) command except that an interruption occurs not for each sector transfer but for each block transfer that consists of the number of sectors defined by SET MULTIPLE command. When the nIEN bit(bit 0 of the Device Control register) is set (1), an interruption does not occur. The number of block counts can be set only 1. Even if WRITE MULTIPLE commands are disabled (Lower byte of IDENTIFY DEVICE command parameter information Word 59), this command can execute.

Inputs

Register	7	6	5	4	3	2	1	0
Feature	na							
Sector Count	Sector Count							
Sector Number	Sector Number or LBA [7:0]							
Cylinder Low	Cylinder Low or LBA [15:8]							
Cylinder High	Cylinder High or LBA [23:16]							
Device/Head	na	LBA	na	0	Head or LBA [27:24]			
Command	C5h							

Sector Count register: The number of sectors to be written (256 sectors are transferred in the case of 00h)

Sector Number register: Starting sector address to be written (CHS: Sector address/LBA: LBA [7:0])

Cylinder Low register: Starting sector address to be written (CHS: Lower cylinder address/LBA: LBA [15:8])

Cylinder High register: Starting sector address to be written (CHS: Upper cylinder address/LBA: LBA [23:16])

Device/Head register: Starting sector address to be written (CHS: Head address/LBA: LBA [27:24]), Drive No.(Fixed 0), LBA flag

Normal outputs

Register	7	6	5	4	3	2	1	0
Error	na							
Sector Count	00h							
Sector Number	Sector Number or LBA [7:0]							
Cylinder Low	Cylinder Low or LBA [15:8]							
Cylinder High	Cylinder High or LBA [23:16]							
Device/Head	na	LBA	na	0	Head or LBA [27:24]			
Status	BSY	DRAY	DWF	DSC	DRQ	CORR	na	ERR

Status register: 50h

Sector Count register: 00h

Sector Number register: Last written sector address (CHS: Sector address/LBA: LBA [7:0])

Cylinder Low register: Last written sector address (CHS: Lower cylinder address/LBA: LBA [15:8])

Cylinder High register: Last written sector address (CHS: Upper cylinder address/LBA: LBA [23:16])

Device/Head register: Last written sector address (CHS: Head address/LBA: LBA [27:24]), Drive No.(Fixed 0), LBA flag

(43) WRITE SECTOR(S) (30h or 31h)

This command is used to write data equivalent to the number of sectors specified in the Sector Count register starting from the sector number specified in the task file register. When the Sector Count register is set to 0, it is processed as data transfer equivalent to 256 sectors.

Inputs

Register	7	6	5	4	3	2	1	0
Feature	na							
Sector Count	Sector Count							
Sector Number	Sector Number or LBA [7:0]							
Cylinder Low	Cylinder Low or LBA [15:8]							
Cylinder High	Cylinder High or LBA [23:16]							
Device/Head	na	LBA	na	0	Head or LBA [27:24]			
Command	30h or 31h							

Sector Count register: The number of sectors to be written (256 sectors are transferred in the case of 00h)

Sector Number register: Starting sector address to be written (CHS: Sector address/LBA: LBA [7:0])

Cylinder Low register: Starting sector address to be written (CHS: Lower cylinder address/LBA: LBA [15:8])

Cylinder High register: Starting sector address to be written (CHS: Upper cylinder address/LBA: LBA [23:16])

Device/Head register: Starting sector address to be written (CHS: Head address/LBA: LBA [27:24]), Drive No.(Fixed 0), LBA flag

Normal outputs

Register	7	6	5	4	3	2	1	0
Error	na							
Sector Count	00h							
Sector Number	Sector Number or LBA [7:0]							
Cylinder Low	Cylinder Low or LBA [15:8]							
Cylinder High	Cylinder High or LBA [23:16]							
Device/Head	na	LBA	na	0	Head or LBA [27:24]			
Status	BSY	DRAY	DWF	DSC	DRQ	CORR	na	ERR

Status register: 50h

Sector Count register: 00h

Sector Number register: Last written sector address (CHS: Sector address/LBA: LBA [7:0])

Cylinder Low register: Last written sector address (CHS: Lower cylinder address/LBA: LBA [15:8])

Cylinder High register: Last written sector address (CHS: Upper cylinder address/LBA: LBA [23:16])

Device/Head register: Last written sector address (CHS: Head address/LBA: LBA [27:24]), Drive No.(Fixed 0), LBA flag

3.3 Firmware Upgrade

- The Firmware of SATA DiskOnModule can not be upgraded by customers, so please contact your nearest CSS Office.

4. Installation

4.1 Installation

- For Installation of SATA DiskOnModule to your system, please follow up below steps;
 1. Make sure your computer is turned off before you open the case.
 2. Plug the SATA DiskOnModule carefully into the Serial ATA slot on your computer or host adapter.
 3. Plug the SATA DiskOnModule into Serial ATA Power Cable with 3.3V
 4. Check cable connections and SATA DiskOnModule is firm enough.

4.2 Partition

- For DOS Operating System :
 - To partition your new SATA DiskOnModule for example use Microsoft DOS program:
 1. Insert a bootable DOS diskette into your diskette drive and restart your computer.
 2. Insert a DOS program diskette that contains the **FDISK.EXE** and **FORMAT.COM** programs into your diskette drive. Use the same DOS version that is on your bootable diskette. At the A: prompt, type **FDISK** and press **ENTER**.
 3. Select "Create DOS partition or logical DOS drive" by pressing **1**. Then press **ENTER**.
 4. Select "**Create primary DOS partition**" by pressing **1** again. Then press **ENTER**. Create your first drive partition. If you are creating a partition that will be used to boot your computer (drive C), make sure that the partition is marked active.
 5. Create an extended partition and additional logical drives as necessary, until all the space on your new hard drive has been partitioned.
 6. When the partitioning is complete, **FDISK** reboots your computer.
 - ※ Note: Make sure to use the correct drive letters so that you do not format a drive that already contains data.
 8. At the A: prompt, type **format c:/s**, where c is the letter of your first new partition, Repeat the format process for all the new partitions you have created.
 9. After you format your SATA DiskOnModule, it is ready to use.

- For Windows Operating System :

- To partition your new SATA DiskOnModule, for example use Microsoft WindowsXP and WindowsXP embedded system :

1. In your windows system. You can Click the 『Start』 → 『Control Panel』 → 『Administrative Tools』 → 『Computer Management』 then select 『Storage』 → 『Disk Manager』 to setup the partition.

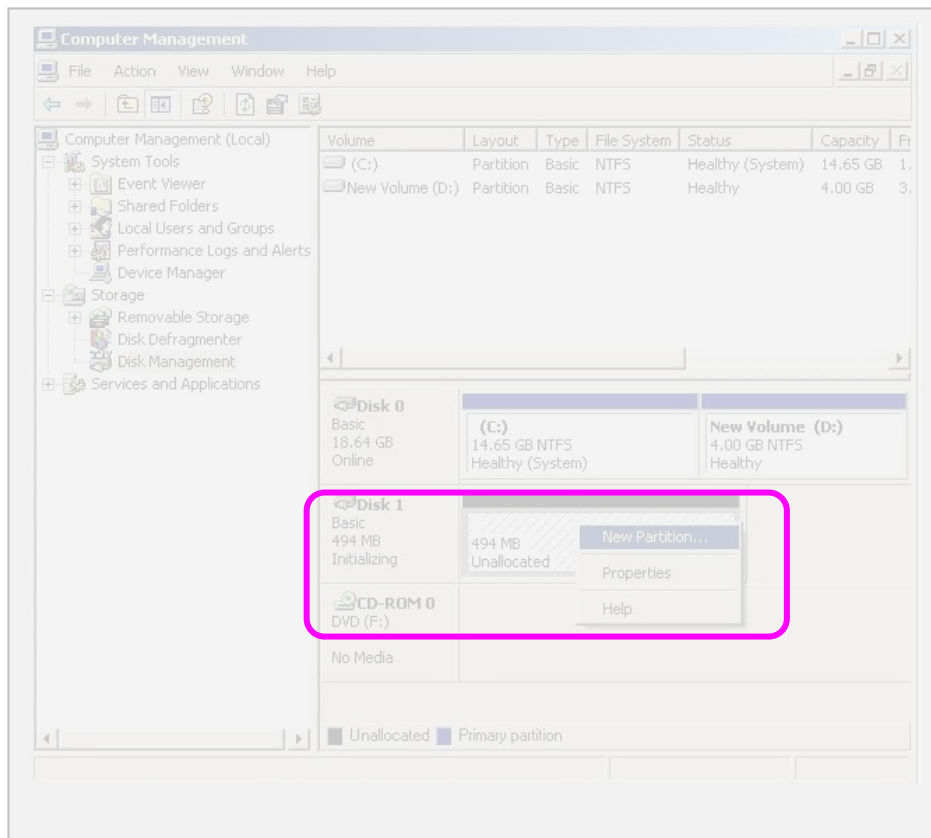

4.3 Format

- For DOS Operating System :

- Before you format or partition your new SATA DiskOnModule, you must configure your computer's BIOS so that the computer can recognize your new SATA DiskOnModule.

1. Turn your computer on. As your computer start up, watch the screen for a message describing how to run the system setup program (sometimes called BIOS or CMOS setup). This is usually done by pressing a special key, such as DELETE, ESC, or F1, during startup. See your computer manual for details. Press the appropriate key to run the system setup program.
2. If your BIOS provides automatic drive detection (an "AUTO" drive type), select this option. (If you use Normal/CHS mode to partition your DOM, you can get the maximum formatted capacity.)

This allows your computer to configure itself automatically for your new SATA DiskOnModule.

If your BIOS does not provide automatic drive detection, select "User-defined" drive setting and enter the CHS values from the table.

BIOS Settings (see specification)

Capacity	Cylinders	Heads	Sectors	(unformatted)
----------	-----------	-------	---------	---------------

3. Save the settings and exit the System Setup program. (Your computer will be automatically rebooted.)

- **For Windows Operating System :**

- To partition your new DOM, for example use Microsoft WindowsXP and WindowsXP embedded system :

1. Click the 『 Start 』 → 『 Control Panel 』 → 『 Administrative Tools 』 → 『 Computer Management 』 then select 『 Storage 』 → 『 Disk Manager 』 to setup the file format.

2. Select “FAT or NTFS” format for user.

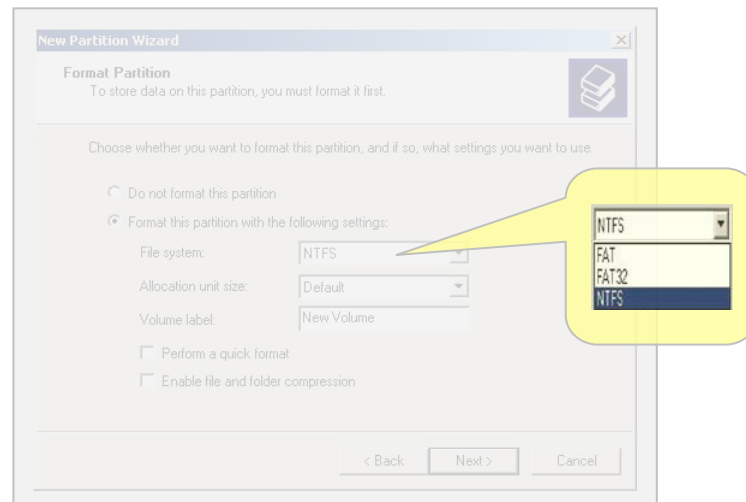

SATA DiskOnModule

5. Troubleshooting

5.1 BIOS can not identify SATA DiskOnModule

- 5.1.1 Check Power Cable Status
- 5.1.2 Check Connector status
- 5.1.3 Check the Power Voltage (only 3.3V)

5.2 SATA DOM can not boot the system

- 5.2.1 Check BIOS setting
- 5.2.2 Reinstall your system

Notice Please contact your closest CSS office for verifying your other troubles.

6. Ordering Information

Table 8: SATA DiskOnModule Ordering Information

P/N	Capacity	Note
HSH11H002GRBC0000	2GB	
HSH11H004GRBC0000	4GB	
HSH11H008GRBC0000	(Max) 8GB	

7. Contact Information

CoreSolid Storage Corporation, a TDK-PQI storage business company, specializes in the design and marketing of SSD, DOM, and Industry CF products.

For further information, please reach us at the following contact information:

Global

- Tel: +886-2-66206168
- Sales: sales@coresolid-storage.com
- Customer Service: support@coresolid-storage.com

US specific

- Tel: +1-408-7257180
- Sales: sales@coresolid-storage.com
- Customer Service: support.us@coresolid-storage.com

China specific

- Tel: : +86-010-82701610
- Sales: sales@coresolid-storage.com
- Customer Service: support.cn@coresolid-storage.com

Europe specific

- Tel: +886-2-66206168
- Sales: sales@coresolid-storage.com
- Customer Service: support.eu@coresolid-storage.com

Japan specific

- Tel: +81-473789423
- Sales: sales@coresolid-storage.com
- Customer Service: support.jp@coresolid-storage.com